


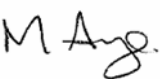
## **CLIENT PROJECT REPORT RPN3680**

# Definition of Direct Vision Standards for Heavy Goods Vehicles (HGVs)

Technical Report

Tanya Robinson, Iain Knight, Philip Martin, Matthias  
Seidl, James Manning, Victoria Evers

## Report details

<b>Report prepared for:</b>	Transport for London, Surface Transport		
<b>Project/customer reference:</b>	tfl_scp_001298		
<b>Copyright:</b>	© Transport Research Laboratory		
<b>Report date:</b>	20 July 2016		
<b>Report status/version:</b>	V1.0		
<b>Quality approval:</b>			
Lisa Collins (Project Manager)		Mike Ainge (Technical Reviewer)	

## Disclaimer

This report has been produced by the Transport Research Laboratory under a contract with Transport for London. Any views expressed in this report are not necessarily those of Transport for London.

The information contained herein is the property of TRL Limited and does not necessarily reflect the views or policies of the customer for whom this report was prepared. Whilst every effort has been made to ensure that the matter presented in this report is relevant, accurate and up-to-date, TRL Limited cannot accept any liability for any error or omission, or reliance on part or all of the content in another context.

When purchased in hard copy, this publication is printed on paper that is FSC (Forest Stewardship Council) and TCF (Totally Chlorine Free) registered.

## Contents amendment record

This report has been amended and issued as follows:

Version	Date	Description	Editor	Technical Reviewer
1.0	20/07/16	Client Project Report	TLR	MJA

<b>Document last saved on:</b>	20/07/2016 16:03
<b>Document last saved by:</b>	Robinson, Tanya L

---

## Table of contents

Executive summary	1
1 Introduction	3
2 Global vision standards	5
3 Where and what do drivers need to see?	8
3.1 Horizontal location – Where do drivers need to see?	8
3.2 Vertical location – What do drivers need to see?	13
3.3 Other vision requirements	14
4 Direct Vision Performance	15
4.1 Proposed assessment method	15
4.2 Options investigated	25
5 Measuring the view	34
5.1 Proposed measurement method	37
5.2 Measurement options investigated	38
6 Implementation of the Direct Vision Standard	54
6.1 Who will carry out the assessment?	54
6.2 How does the assessment apply to a range of vehicle specifications?	54
6.3 Control of unintended consequences	55
7 Stakeholder engagement	56
8 Conclusions & future considerations	58
9 References	60

---

## Executive summary

Transport for London's Safer Trucks Programme aims to accelerate the development, supply and wider uptake of safer Heavy Goods Vehicle (HGVs). A particular goal is to improve the safety performance of vehicles during low speed manoeuvres that result in the death or serious injury of a significant number of pedestrians and cyclists in London each year.

Blind spots around HGVs have long been identified as a potentially significant contributor to the cause of serious collisions with pedestrians and cyclists. A range of up to six mirrors and other field of view aids are already required to improve the view of these areas. However, these measures rely on the driver looking at the correct mirror or vision aid at the right time to be successful and there are concerns that further increases in the number of devices would overload the driver during critical manoeuvres.

Seeing a pedestrian or cyclist directly through the windows of the vehicle is likely to have several advantages over indirect view through mirrors or camera monitors. The image is full size, free from distortions, substantial movement may be visible which would help attract the attention of the driver and direct eye contact is possible between both parties. The benefits of direct vision are being studied as part of separate but complementary research sponsored by Transport for London (TfL), due for completion Autumn 2016.

Regulations exist to define the minimum standard of direct vision from passenger cars to ensure a minimum size of clear glazed area and particularly to control the number and size of pillars obscuring vision in the forward field of view. International standards (e.g. ISO5006) exist for earth moving machinery. However, no technical standards exist which prescribe minimum standards of direct vision from HGVs.

Cyclists killed and seriously injured at the nearside of trucks turning left have historically been the highest profile crashes related to HGVs in low speed manoeuvres. However, research has identified that the area of greatest risk extends across the full width of the front of the vehicle and 5 metres back down the nearside of the vehicle. Within this area of greatest risk, the nearside zone is considered relevant to a larger number of London pedestrian and pedal cyclist casualties than the front zone (this is reversed if GB is considered as a whole where the front zone is more relevant).

Two manoeuvres are responsible for these crashes, the vehicle moving off from rest and the vehicle turning left.

- In crashes during moving off from rest, a vulnerable road user (VRU) - usually a pedestrian, occasionally a cyclist - is crossing in front of a stationary HGV and can't be seen directly by the driver. Traffic lights turn to green, or traffic ahead moves off, and the HGV moves forward running over the vulnerable road user. Casualties are disproportionately elderly. Vehicles with good direct vision performance would enable the vast majority of these vulnerable road users to be seen by an attentive driver at a time that would permit the collision to be avoided.
- Turning left crashes usually involve cyclists but occasionally involve pedestrians. The impacts typically occur at the nearside towards the front, though some also occur further back down the side of the vehicle. The dynamics of the pre-collision motion can

be complex and can mean that a significant proportion of bicycles will have been positioned to the rear of the HGV cab at the key moment that would permit an attentive driver to avoid the collision. Direct vision is less feasible in this area. Thus, only the proportion of these casualties positioned nearer to the front of the vehicle would be expected to be visible to an attentive driver at the key moment required to avoid collisions.

This research project carried out as part of the Safer Trucks Programme, funded by TfL, has defined a direct vision assessment for HGVs. This assessment will allow the VRU relevant direct vision in close proximity to any HGV to be reliably and robustly measured and its performance in relation to VRU safety to be categorised using a five star rating scheme. The five star rating rewards small improvements to the direct vision performance and avoids the use of descriptive category titles that could be open to interpretation.

The assessment protocol defines:

- A measurement method based on a 'virtual assessment' of the available view through the windows using 3D Computer Aided Design (CAD) techniques.
- Assessment zones based on collision data and the range of human dimensions in the population.
- Vehicle performance rating scheme from zero to five stars.

Application of the rating scheme to a sample of HGVs showed that:

- A typical, off-road specification HGV, assessed in its basic form would achieve zero stars. Relatively low cost modifications such as adding a low side window or re-shaping the dashboard may improve their performance to achieve one star.
- Typical on-road specification vehicles achieved two or three stars.
- A vehicle with a low-entry, panoramic cab achieved a rating of five stars.

---

## 1 Introduction

In Greater London, the number of vulnerable road users (pedestrians and pedal cyclists) that are killed or seriously injured in collisions involving Heavy Goods Vehicles (HGVs) is disproportionate to those involving other types of vehicle. Construction type vehicles (e.g. 4 axle rigid tippers) are substantially over-represented in the data regarding these collisions for the proportion of traffic for which they account.

Transport for London is committed to a target of a 50% reduction in the number of people killed or seriously injured on London's roads by 2020 (from the 2005-9 baseline). Reducing vulnerable road user casualties caused by collisions with HGVs is seen as a key contributor towards meeting that goal.

TfL is exploring the options available to encourage the use of vehicles with improved direct vision through both voluntary and contractual measures. It is also considering efforts to encourage legislation to provide minimum standards of direct vision for HGVs through the European Type Approval framework. A technical standard is therefore required for immediate use by TfL; with the possibility that the assessment protocol may also form the basis for contractual conditions and a directive or regulation in the future.

The overall aim of this project was to develop a direct vision assessment protocol that allowed reliable and precise measurement of the direct vision from HGVs and categorised the vehicle vision performance in terms relevant to vulnerable road user safety. The assessment protocol was expected to categorise the vehicles based on the ability of the driver to see vulnerable road users in close proximity to the vehicle where there is potential for conflict between the two.

The objectives specified by TfL were that 3 categories of direct vision should be defined and that even the lowest level would produce an increased view in comparison to a standard construction sector HGV with off-road specifications. TfL identified three classes of vehicle with different standards of direct vision that they would like the direct vision protocol to discriminate between:

- Off-road specification construction vehicles equipped with small enhancements such as the addition of a low level side window in the passenger side door.
- Typical on-road specification vehicles.
- Specialist low entry vehicles with panoramic windows such as a Mercedes Econic or a Dennis Eagle Elite, typically used in the refuse sector.

The project involved:

- Analysing collision data, the dynamic events leading to relevant collision mechanisms and road geometries in order to define areas around the vehicle where it was important to be able to see; the area of greatest risk.
- Modelling eight vehicle designs in order to assess how the vision performance of the vehicle could be quantified into appropriate performance bands.
- A review of the scientific literature and existing standards with respect to the measurement of field of view and definition of human visual characteristics.

- 
- Engaging with stakeholders to ensure the protocol developed was well suited to its expected use.

For this research, the relevant stakeholder groups were identified as vehicle manufacturers, vehicle operators and regulators, all of which have a vested interest in the outcomes of this project. One to one meetings or telephone interviews were completed with the major UK manufacturers of HGVs. Vehicle operators were consulted through telephone interviews and involvement in Construction Logistics and Cyclist Safety (CLOCS) meetings.

TfL and TRL would like to thank all those who contributed to this process, which has helped to define the proposed Direct Vision Protocol for HGVs.

This report describes the technical background to the assessment protocol and the main findings and conclusions of the research. A separate summary report is available. A separate Technical Standard document has been prepared in a format consistent with ISO standards in order to allow those assessing the vehicles to undertake testing in accordance with the process described here.

---

## 2 Global vision standards

There are a wide variety of procedures, proposed both in standards and by original research studies, which already relate to measuring the direct fields of view from vehicles. However, none of the standards identified and reviewed could be applied directly to meet the objective of this project. Most standards applied to other types of vehicle, such as earth moving machinery and passenger cars. Methods applied to HGVs tended to consider a wider field of view and also included in-direct vision.

To ensure the transfer of current best-practice to this direct vision protocol for HGVs, the standards and procedures were systematically identified and critically appraised via a literature review. The strengths and weaknesses of each procedure were assessed with respect to stakeholder requirements.

The literature review of the existing procedures was performed in a four stage process. The first stage was a structured search of both the standards and literature databases available to TRL to identify all procedures relevant to direct vision. The second stage identified the main characteristics of the procedural aspects of the literature sources. Where more than one approach was identified, these were considered for inclusion in the Direct Vision Standard. Stage 3 critically appraised the advantages and disadvantages of these options. As the primary outcome of this review, the final stage provided recommendations on current best-practice.

Summaries of each procedure, used either by a standard or original research study, are provided in Appendix B. A commentary is provided on their procedural approach and strengths and weaknesses are discussed with respect to stakeholder requirements for this specific application. The documents upon which the Direct Vision Assessment Protocol has been developed are shown in Table 2.1.



**Table 2.1. Overview of standards and methods reviewed**

Article	Referenced procedures	Issued by	Year	Objective
<b>ACEA, Jama, Kama proposal for a consumer visibility test</b>	n/a	Automotive industry associations (ACEA, Jama, Kama)	2004	Voluntary proposal for M1 vehicles. Proposed testing procedures and assessment criteria to determine the regions of direct and indirect visibility available to passenger car drivers. Developed by the automotive industry as counter proposal to TRL’s PNCAP proposal; not implemented in legislation or consumer testing.
<b>CLOCS/LDS-2015</b>	UMTRI-2005-30	Loughborough Design School (LDS)	2015	Research considering N3 vehicles. Assessment and comparison of the direct and indirect field of view between the best-selling HGVs in London as part of TfL’s CLOCS programme. No specific test protocol was defined.
<b>CLOCS/TRL-2013</b>	n/a	Transport Research Laboratory (TRL)	2013	Research considering N3 vehicles. Assessment of direct and indirect visibility from three exemplary HGV cabs performed as part of TfL’s CLOCS programme. No specific assessment protocol was defined.
<b>FMVSS 104</b>	SAE J941 SAE J903a	National Highway Traffic Safety Administration (NHTSA)	1996	Regulates the forward field of vision of the driver by defining the minimum area that has to be swept by the windscreen wipers. (Implicit definition of minimum direct vision zones). Applies to cars, MPVs, trucks and buses.
<b>FMVSS 111</b>	SAE J941 SAE J903a	National Highway Traffic Safety Administration (NHTSA)	1999	US legislation for range of vehicles including trucks. Regulates indirect driver vision through two assessment procedures: The procedure for cars, multi-purpose vehicles, trucks and buses only describes minimum zones rearward of the vehicle. The procedure for school buses provides specific regulation of the external area surrounding a school bus.
<b>Heavy Vehicle Aggressivity Index (HVAI)</b>	n/a	APROSYS Consortium (led by TRL)		Voluntary protocol for N2 vehicles over 7.5t and N3 vehicles. Assessment procedure for the aggressivity of the vehicle design of HGVs of cab-over-engine configuration, including a field of view assessment. Developed as part of the research project APROSYS; not implemented in legislation or consumer testing.
<b>ISO 4513</b>	n/a	Technical Committee ISO/TC 22	2010	Technical standard applicable to all vehicle types. Describes eye point locations for the driver of a vehicle as eyellipses, i.e. statistically derived elliptical models in three dimensions representing cut-off percentiles for the driver eye point locations.
<b>ISO 5006</b>	ISO 5353	Technical Committee ISO/TC 127	2006	Technical standard for earth-moving machinery including procedures and performance requirements to assess direct and indirect field of view for the operators.

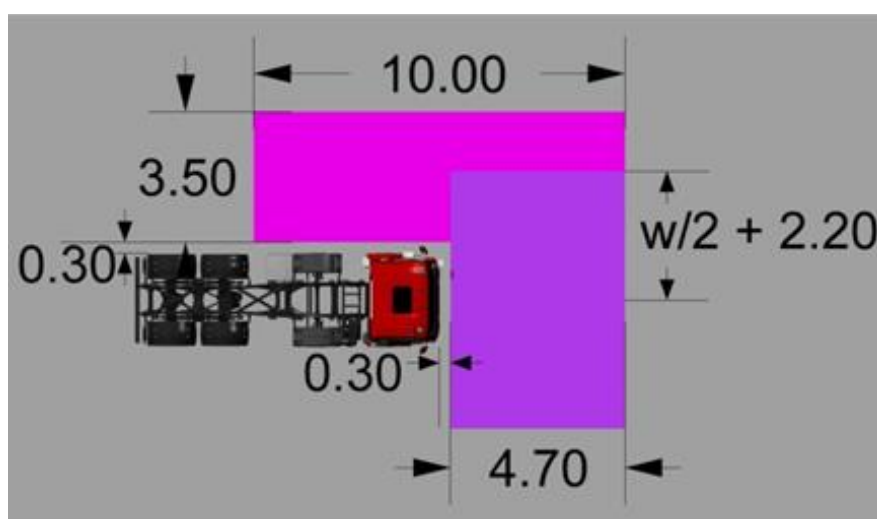
Article	Referenced procedures	Issued by	Year	Objective
<b>ISO 7397-1 and -2</b>	ISO 20176	Technical Committee ISO/TC 22	1993	Technical standard for passenger cars. Test methods for verifying the compliance of a passenger car with the requirements of EEC Directives 77/649 and 88/366 for the 180° forward field of view of the driver.
<b>ISO 14401-1 and -2</b>	n/a	Technical Committee ISO/TC 127	2009	Technical standard for earth-moving machinery. Testing procedures and performance assessment criteria for evaluating the field of vision of operators using surveillance and rear-view mirrors on earth-moving machinery.
<b>Japanese Safety Regulations, Article 44</b>	ISO 20176	Ministry of Land, Infrastructure and Transport (MLIT)	Unknown	Legislation for cars, heavy duty trucks (cab-over-engine type, less than 8 tonnes). Performance-based minimum requirement for visibility of areas in vicinity of a vehicle. Combined assessment of direct and indirect vision.
<b>NHTSA 2008 rear visibility assessment</b>	n/a	National Highway Traffic Safety Administration (NHTSA)	2008	Research based on cars, SUVs and pickup trucks. Testing procedure developed during the course of a research project to determine the range of rear visibility blind zones of light vehicles.
<b>PNCAP Visibility Protocol</b>	SAE J826	Transport Research Laboratory (TRL)	2005	Voluntary protocol for passenger cars. Proposed testing procedures and assessment criteria to determine the regions of direct and indirect visibility available to passenger car drivers. Developed in a DfT-funded research project; not implemented in legislation or consumer testing.
<b>SAE J903a</b>	n/a	SAE Technical Standards Board	1966	Technical standard for passenger cars. Testing procedures and minimum performance requirements for passenger car windscreen wiping systems. Defines minimum wiped area, and thus implicitly minimum direct vision zones.
<b>SAE J941</b>	n/a	SAE Technical Standards Board	2010	Technical standard for all vehicle types. Describes the eyellipse, a statistical representation of driver eye locations, which is used to facilitate design and evaluation of vision in motor vehicles.
<b>UN Regulation No. 46</b>	ECE R.E.3	World Forum for Harmonization of Vehicle Regulations (WP.29)	2013	Legislation for category M and N vehicles. Requirements and testing procedures for devices for indirect vision (mirrors, cameras, etc.).
<b>UN Regulation No. 125</b>	ECE R.E.3	World Forum for Harmonization of Vehicle Regulations (WP.29)	2013	Legislation for category M1 vehicles. Requirements and testing procedures regarding the forward field of direct vision of the motor vehicle driver.

### 3 Where and what do drivers need to see?

An analysis of where and what drivers need to see was based on reviews of high level collision data, in-depth analysis of the detailed motion of the parties in individual cases and data defining the typical and extreme sizes of people. This allowed an assessment of how much of a short, average, or tall person can be seen in any particular position around the vehicle and where an attentive driver would be likely to see the VRU at the time required to enable them to react appropriately and avoid a collision. The result was the definition of 3-dimensional zones at the front and nearside of the HGV. The definition of these zones is described in more detail in the following sections and Appendix A.

#### 3.1 Horizontal location – Where do drivers need to see?

The location of pedestrians around the vehicle at the critical moment at which the driver would need to take action to avoid a collision was found to typically fall into the horizontal zones on the ground defined in, below.



**Figure 3.1. Front and nearside zones where direct vision is required<sup>1</sup>.**

The dimensions are based on consideration of where the centre-line of a vulnerable road user might be, which is why the position closest to the vehicle is 0.3m. This allows space for the width of the shoulder from the centre of the chest while still allowing for some clearance between the widest part of the person and the vehicle.

The remaining dimensions were based on the analysis of collision data. Firstly, the high level statistics (see Table 3.1) in London showed that vulnerable road users (mainly pedal cyclists) killed by the nearside of an HGV turning left represented the largest group of HGV collisions where the vulnerable road user was likely to have been in close proximity to the HGV in the seconds immediately prior to the collision. Those (mainly pedestrian) killed where the front of the HGV collides with a VRU when the HGV is moving off from rest were the next most significant group.

<sup>1</sup> The lighter shaded area is the nearside zone, the darker is the frontal zone. In the dimensions, W designates the width of the vehicle, which may vary for different models.

**Table 3.1. London vulnerable road user fatalities by manoeuvre group and impact point.**  
 Source: Stats 19 2005-2014<sup>2,3</sup>

VRU Type	HGV Manoeuvre	10 year annual average 05-14			
		1st point of impact (HGV)			Total
		Nearside	Front	Offside	
Pedestrian	Moving off	0.4	2.1	0.1	3.6
	Turning left	0.5	0.2	0.1	
	Turning Right	0	0.1	0.1	
	Not vision relevant	0.9	2.5	0.3	3.7
Pedal Cyclists	Moving off	0.4	0.2	0.1	3.3
	Turning left	2.2	0.1	0.1	
	Turning Right	0	0.1	0.1	
	Not vision relevant	0.8	0.2	0	1
All	Not vision relevant	1.7	2.7	0.3	4.7
	Vision Relevant	3.5	2.8	0.6	6.9
	Weighting (VR)	50.7%	40.6%	8.7%	100.0%

**Table 3.2. GB vulnerable road user fatalities by manoeuvre group and impact point.**  
 Source: Stats 19 2005-2014<sup>3</sup>

VRU Type	HGV Manoeuvre	10 year annual average 05-14			
		1st point of impact (HGV)			Total
		Nearside	Front	Offside	
Pedestrian	Moving off	0.9	7.7	0.2	13
	Turning left	1.7	1.1	0.1	
	Turning Right	0.3	0.8	0.2	
	Not vision relevant	6.7	26.6	1.4	34.7
Pedal Cyclists	Moving off	1.4	1.2	0.4	17.6
	Turning left	10	2	0.6	
	Turning Right	0.2	1.4	0.4	
	Not vision relevant	7.6	6.8	1	15.4
All	Not vision relevant	14.3	33.4	2.4	50.1
	Vision Relevant	14.5	14.2	1.9	30.6
	Weighting (VR)	47.4%	46.4%	6.2%	100.0%

<sup>2</sup> Note that figures for London are based on collisions reported by Metropolitan and City of London Police forces

<sup>3</sup> The vehicles involved are all coded as an HGV>7.5 tonnes. Research has suggested that a significant number of construction bodied HGVs (e.g. tippers/cement mixers) get incorrectly coded in Stats 19 as Other Motor Vehicles. Data available for pedal cyclists only suggests that including incorrectly coded HGVs would add an average 2.1 fatalities/yr to the total to make 5.4. Data is not available for pedestrians and similar proportions of mis-coded vehicles are quite possible.

This analysis showed that, in London, more pedestrians were killed in low speed manoeuvres (excluding reversing) than pedal cyclists. Very few collisions involved the offside of the vehicle and, overall, for London, the nearside of the vehicle was slightly more important than the front. This distribution for London differs to Great Britain (GB) as a whole (Table 3.2), where cyclists are more frequently killed than pedestrians in low speed manoeuvres and the importance of front and nearside areas is more equal (although a slight bias to the nearside is present in the data).

### 3.1.1 Moving off scenario

The dynamics of 'moving off' collisions are relatively simple, with the scenario illustrated in Figure 3.2.



**Figure 3.2. Illustration of moving off collision scenario, pedestrians not visible (left) and partially visible (right)**

A pedestrian walks, or pedal cyclist cycles or pushes their bike, in front of a stationary HGV to cross the road. While the VRU is crossing, traffic lights change to green or traffic moves forward. If the VRU is positioned in the vehicle blind spot as shown in Figure 3.2 (left) and is not seen by the driver, the driver pulls away from rest and collides with the VRU. If the VRU can be easily seen, then the driver is less likely to move the vehicle, avoiding the collision.

An impact could potentially occur in any lateral position across the front of the vehicle. The worst case is when a pedestrian walks very close to the front of the vehicle. For this scenario, data relating to the geometry of the UK population (anthropometric data) has informed an estimate that this would mean the centreline of the VRU could be positioned as close as 0.3m in front of the vehicle.

At the time the driver needs to make a decision (up to 1.5 seconds before pulling away), the VRU could be outside the path of the vehicle. How far outside the vehicle path will depend on the moving speed of the VRU, with the worst case being slow movement. Accident analysis (see Appendix A) shows that most fatalities are elderly (more than half are over 75 years) and therefore average moving speeds can be estimated at around 5.2

km/h. This suggests that at the critical moment the VRU could be up to 2.2m outside the path of the vehicle.

As the VRU is positioned further away from the front of the vehicle, so the risk will diminish. The accident dynamics cannot provide a definitive end point at which there is no risk of a 'moving off' collision. That boundary is likely to be defined by the distance at which a substantial proportion (assumed to be all above 0.93m) of the VRU can be seen by all trucks on the road. Thus, the appropriate dimension of this element of the area of greatest risk should be defined from the modelling of vehicles and, for the vehicles assessed has been shown to be 4.7m.

### 3.1.2 *Turning left scenario*

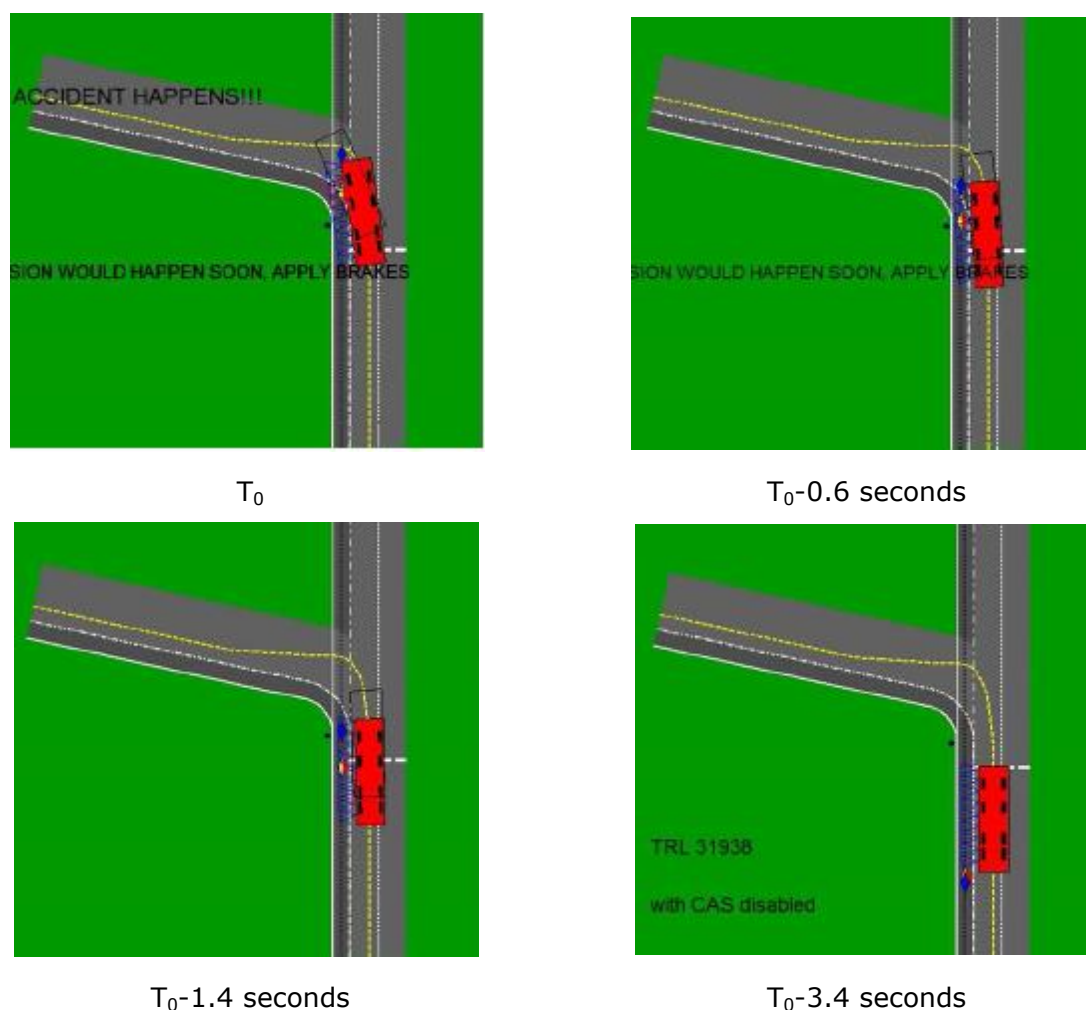
The turning left scenario is dynamically more complex and the in-depth collision data studied allowed for at least three sub-types to be considered:

1. The pedal cycle moves up the nearside of an HGV stationary at traffic lights. This is the most common scenario (40% to 70% depending on data source). It is characterised by high speed differences between vehicles and significant changes in relative position of vehicles throughout the manoeuvre, particularly in the early stages. Impact points are typically at the nearside front, around the area of the front and second axles of a traditional 4 axle tipper. However, at the moment when the driver would need to react to avoid a collision the cycle can be positioned further back, up to around 5 or 6m rear of the front of the vehicle. An example of the reconstruction of a collision of this type is shown in Figure 3.3. Source: (Jia, 2015).
2. Both vehicles are stationary before moving off from rest together. This scenario is characterised by lower speed differentials and smaller changes in relative position of vehicles. The cycle was sometimes initially positioned ahead of the vehicle with the HGV, then overtaking slightly in the moments before collision. Other times the HGV was initially ahead with the pedal cycle undertaking slightly before the collision. Impact points were almost all at the nearside front of the vehicle, typically around the position of the front axle.

Improved direct vision may or may not enable the cyclist in this scenario to be seen at the critical moment. For collisions with impact points further back and/or higher relative speeds, the cyclist will be positioned quite far back and potentially moving through the zone. The load carrying body of the HGV will limit the line of sight in this area even if the cab were engineered with windows theoretically allowing the view. In addition to this, to exploit the view available, the driver would have to undertake a substantial turn of the head. It is unlikely that all drivers would do this in all turns and, if they did, it would increase workload and may distract attention from other important areas of view. However, improvements would allow the cyclist to be seen in direct vision at points further forward which will allow the opportunity to avoid some of the collisions and for some others the opportunity to stop the vehicle before the victim is subsequently run over by the wheels.

3. Both vehicles moving. These collisions are also characterised by lower speed differentials and smaller changes in relative position of vehicles in the moments immediately prior to impact. However, impact positions varied randomly along the length of the side of the vehicle from the front to the position of the rear axle. Thus, the position of the cyclist at the critical moment for detection could be anywhere from the nearside front corner to quite close to the rear of the vehicle, around 8.5m rear of the front of a rigid tipper but potentially much further rearward for an articulated vehicle.

Those collisions with impact points towards the front of the vehicle could be affected by improvements to direct vision. However, those with impact points to the rear will clearly not be affected because it will not be possible to provide direct vision in that area.



**Figure 3.3. Simulation of a real-world fatal collision involving a cyclist and a left turning HGV in circumstances consistent with scenario 1. Source: (Jia, 2015)**

Collision data from GB did not typically identify the distance between the side of the HGV that was about to turn left and the pedal cyclist. This lateral separation distance was identified in some German data that was analysed. (Schreck & Seiniger, 2014) found that accidents typically involved up to 5m lateral distance between the HGV and the cyclist prior to the turn, which is in excess of a full UK lane width and would have implied



the need for a wider vision zone at the nearside. However, this may be influenced by the fact that many of the collisions recorded in the German data occurred in situations where a segregated cycle lane was present (example shown in Figure 3.4, below), which would tend to increase separation. This situation may be less relevant in the UK, where most collisions occur at locations that do not have separated cycle lanes. However, this may need monitoring in the future if segregated cycle lanes are increasingly adopted in GB and London.

It should be noted that (Schreck & Seiniger, 2014) stated that conclusions on the effectiveness or safety of segregated cycle lanes could not be drawn on the basis of their analysis because there was no comparison between collision rates with and without segregated cycle lanes and these were considered particularly prevalent in the region the accident study was undertaken.



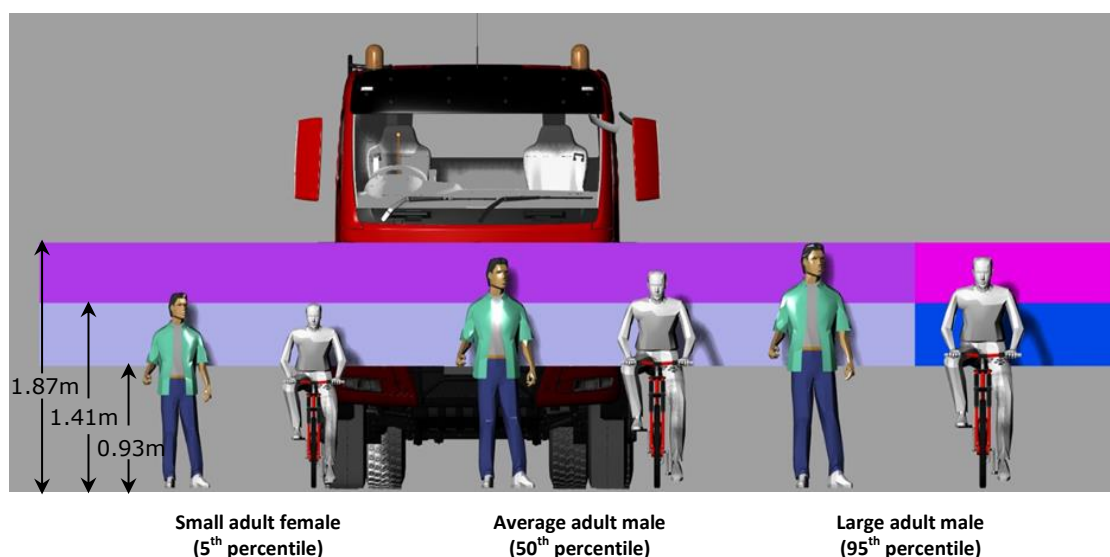
**Figure 3.4. Examples of separated cycle lanes with potential line of sight obstruction in Germany. Source (Schreck & Seiniger, 2014).**

### 3.2 Vertical location – What do drivers need to see?

The analysis of horizontal location defined where it is important to assess direct vision around the vehicle. However, it is also important to consider what must be seen. For example, it is clear that just being able to see a thin slice of the top of a cyclist's head, or the feet of a pedestrian, may not be enough to attract the attention of an HGV driver quickly and reliably enough. It is also clear that you do not need see the whole of a vulnerable road user from head to foot to quickly recognise them and assess the risk of a collision with them. No scientific evidence was identified that quantified the likelihood, speed or accuracy of recognition, which will be studied in separate research under the Safer Trucks programme. In the absence of specific information, it has been assumed that the maximum recognition rate would be achieved when a person could be seen from the waist up.

People come in a wide variety of shapes and sizes, such that their waist height and their overall height vary considerably. Analysis of collision data showed that children were very rarely involved in these types of collision either as pedestrians or cyclists. For pedestrians, there was a strong bias towards elderly people, in particular females. This led to the vertical definition of the zones as illustrated in Figure 3.5.





**Figure 3.5. Vertical definition of visibility zones**

The lowest height (0.93m) corresponds to the waist height of a 5<sup>th</sup> percentile female, 1.41m to the overall height of a 5<sup>th</sup> percentile female and 1.87m to the overall height of a 95<sup>th</sup> percentile male. As such, if the upper zone is completely visible, then 95 % of all adult VRUs can be seen at least to some extent. However, only the tallest will be visible to a level at the centre of the chest or below. Visibility in the lower zone is required to allow the smallest 5% of the adult population to be visible at all and will increase the proportion of each larger person that can be seen, thus potentially helping them to be quickly and correctly recognised.

### 3.3 Other vision requirements

Based on the casualty analyses, the greatest risk for VRUs is clearly at the nearside and front of the HGV. However, the reason for a low risk at the offside of the vehicle may, at least partly, be because of good existing direct vision in that area. The same may be true of other driving circumstances; there are few fatal crashes affected by blind spots because the vision in those areas is already good, with the possible exception of areas obscured by A-pillars and mirror clusters.

There are currently no legislative requirements relating to the direct field of view from HGVs. As such, the only type approval requirement placed on direct vision is that applied by the requirements for in-direct vision. Effectively the direct vision must be sufficient to allow a driver to see the mirrors. Thus, all of the areas with good field of view are currently achieved voluntarily by market forces.

However, the intention of defining an assessment procedure to categorise the field of view in the zone of greatest risk is to encourage manufacturers to change the design of vehicles. Therefore, it is possible that those design changes could improve performance in the zone of greatest risk at the cost of reduced performance in other areas. While market forces would be expected to prevent any extreme reductions, some trade-offs may be made in the absence of any other incentives and the situation should be monitored.

## 4 Direct Vision Performance

### 4.1 Proposed assessment method

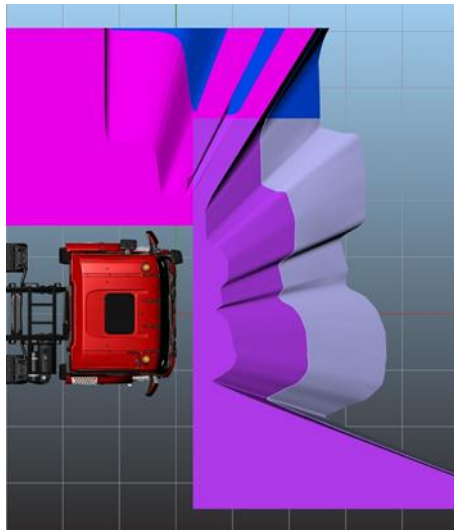
The vision performance of a vehicle is quantified within the Direct Vision Assessment Protocol document. The method defined is intended to take the physical measurements of the glazed areas and convert these to a five star rating scheme that categorises the view available. The assessment is intended to correlate closely to the likelihood of a driver being able to see and recognise a vulnerable road user in close proximity to the vehicle in the two key manoeuvres that lead to fatalities in London (as described in the previous sections).

It was also important to consider how each of these performance bands would align with the vehicle types identified by TfL as benchmarks. Thus, a modelling exercise was undertaken and four vehicles were assessed according to the principles that were considered for inclusion in the final assessment protocol. These vehicles were; an off-road specification N<sub>3</sub>G<sup>4</sup> construction vehicle, a typical on road specification N<sub>3</sub> rigid vehicle, an on-road specification N<sub>3</sub> tractor unit for an articulated vehicle; and a low-entry panoramic cab. The N<sub>3</sub>G and N<sub>3</sub> rigid vehicle models were also assessed in two modified states. The first of these was to assess the effect of adding a low level window in the passenger door. Secondly, the potential effect of re-shaping the dashboard was assessed because in many cases this is the factor that first limits the view of vulnerable road users in close proximity to the front of the vehicle. For these examples, the maximum effect of that measure was simulated by the simplistic method of removing the dashboard entirely. As a stand-alone measure removing the dashboard is not realistic but it illustrates the maximum possible benefit of cleverly designing the dashboard without changing the fundamental geometry of the cab structure to lower the bottom edge of the windscreen. The results from the assessment of the influence of the dashboard are shown in Figure 4.1 below.

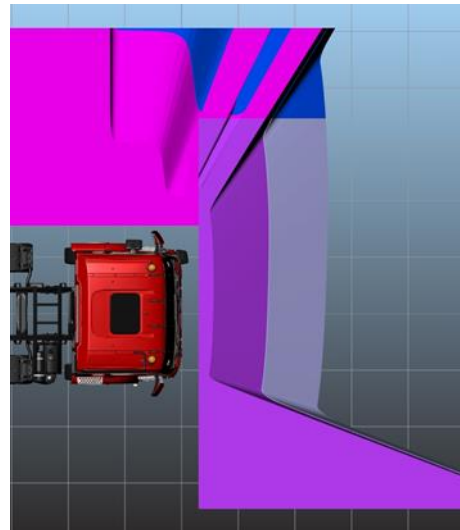
The images on the left show the standard dashboard and the rounded areas represent space that is not visible as a result of parts of the dashboard obscuring the view. The ‘bulge’ directly in front of the driver for the N<sub>3</sub>G vehicle is clearly large enough to conceal a small pedestrian and could be eliminated by dashboard re-design without affecting cab structure as shown in the image on the right.

---

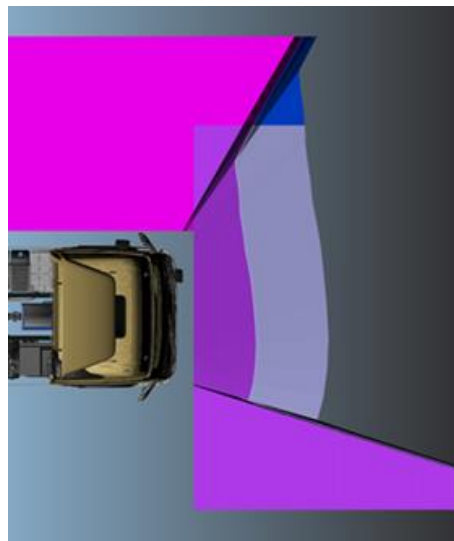
<sup>4</sup> N<sub>3</sub> is a type approval definition of vehicle category meaning a goods vehicle in excess of 12 tonnes gross weight. The sub-category G designates an off-road specification.



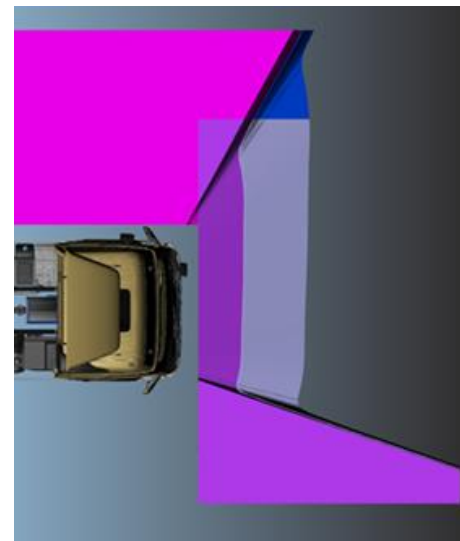
N<sub>3</sub>G rigid with dashboard



N<sub>3</sub>G rigid dashboard removed



N<sub>3</sub> rigid with dashboard

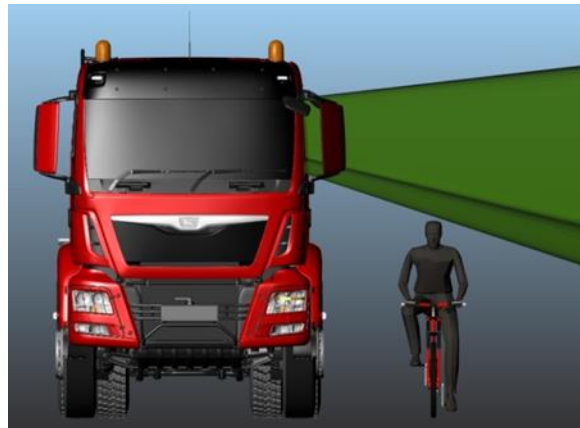
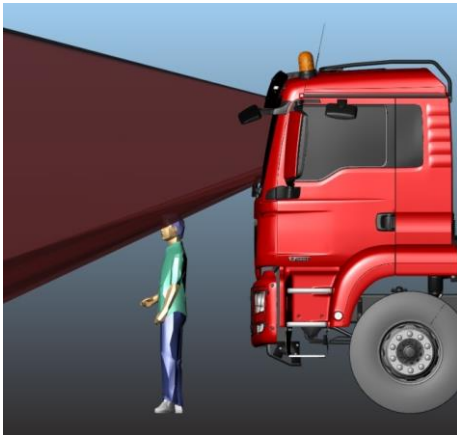


N<sub>3</sub> rigid dashboard removed

**Figure 4.1. Maximum effect of remodelling the dashboard of N<sub>3</sub>G (top) and N<sub>3</sub> (bottom) vehicles on visible space (shaded volumes are not visible).**

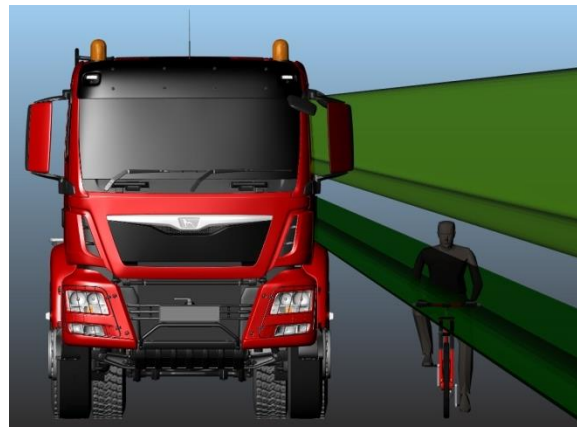
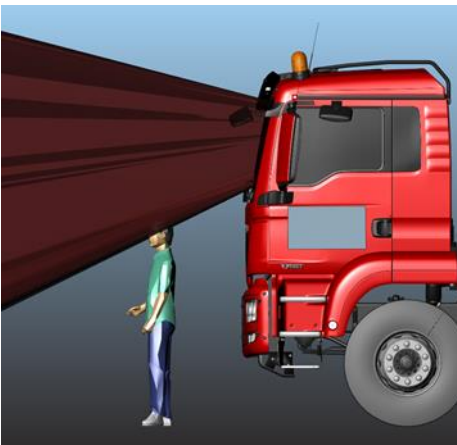
The following images illustrate the front and side view available to the remaining vehicle specifications. A 95<sup>th</sup> percentile male pedestrian or cyclist is positioned where they would just be invisible to the driver of a standard N<sub>3</sub>G vehicle, in front of the vehicle or to the nearside, respectively.

**Table 4.1. Comparison of vehicles from different vision bands based on the TfL Direct Vision Standard**



**Standard N<sub>3</sub>G off-road vehicle**

Part of the pedestrian’s head is visible at some positions along the front of the vehicle but not at others. This is a function of the variable profile of the dashboard, which was illustrated in Figure 4-1 (left). None of the cyclist can be seen at this location.



**N<sub>3</sub>G vehicle – modified to add low level passenger door window**

As expected, the addition of a low side window does not affect vision directly in front of the vehicle. The torso of the cyclist is now partially visible when positioned directly alongside the cab, but this additional effect does not extend very far to the rear of the door position.



**Standard N3 on-road rigid vehicle**

The head of both the pedestrian and the cyclist are visible from this vehicle



**N3 on-road rigid vehicle – modified to add low level passenger door window**

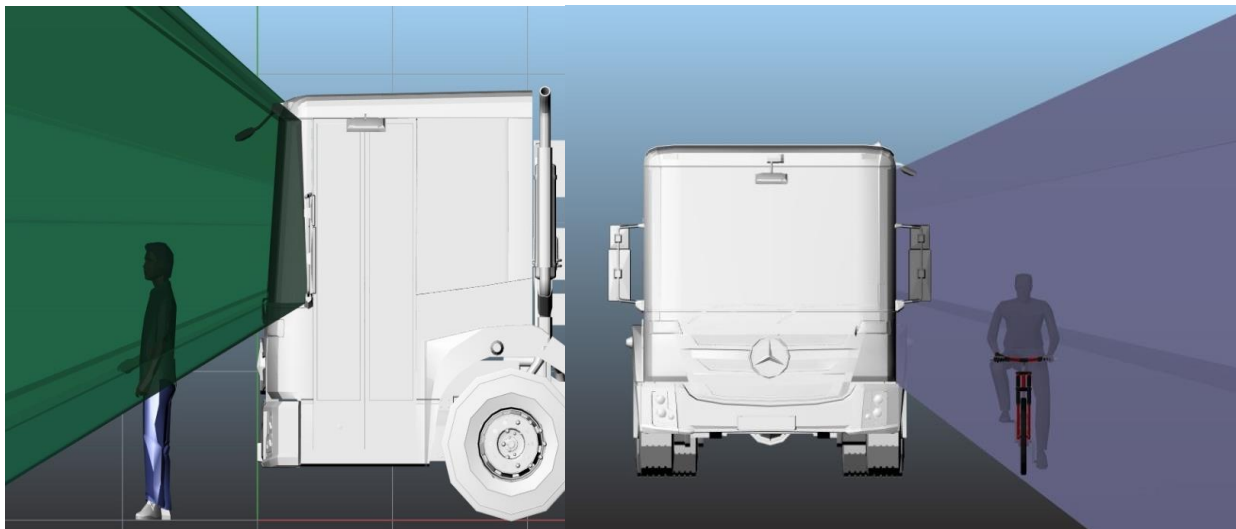
As expected, the addition of a low side window does not affect vision directly in front of the vehicle. The torso of the cyclist is now partially visible when positioned directly alongside the cab, but this additional effect does not extend very far to the rear of the door position. The obstruction to the field of view caused by the passenger seat means that only the arms and front of the cyclists torso have become visible with the addition of the side window (Figure 4.2)





**Standard N3 on road articulated vehicle**

The head and shoulders of both the pedestrian and cyclist are visible



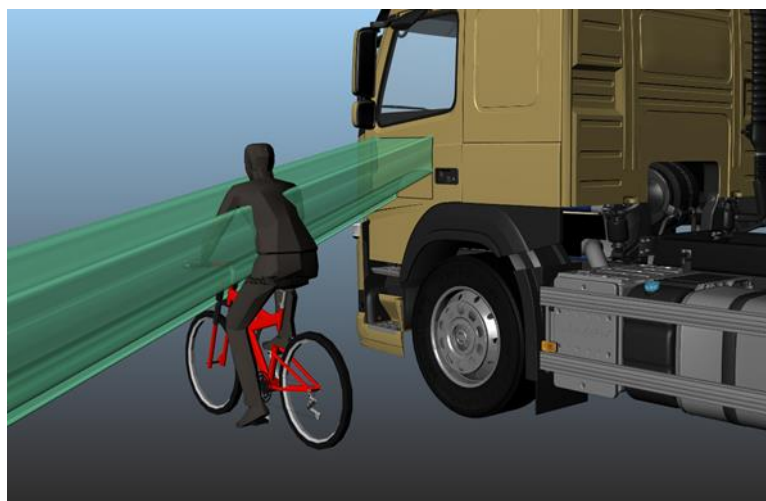
**Low entry panoramic cab**

The pedestrian in this position is visible from the waist up

The cyclist is fully visible in this position, although it should be noted there is the possibility that the cyclist could be partly obscured if they were positioned further back in the blind spot created by the door hinge.

It can be seen that the view from the standard N3G vehicle is very limited in respect of vulnerable road users in close proximity. Introducing a passenger door window at a low level increases the amount of a VRU that is visible but only in a very defined location immediately adjacent to the door. The potential benefit is also strongly correlated to the size of the window. While the front view of the cyclist suggest that the additional side window will allow a proportion of the cyclist to be visible, Figure 3 2 shows that it is only the front part of the torso and the arms that can be seen because of obstruction caused by the passenger

seat. Cyclists may not be in this position at the critical moment the driver needs to see them to avoid the collision.



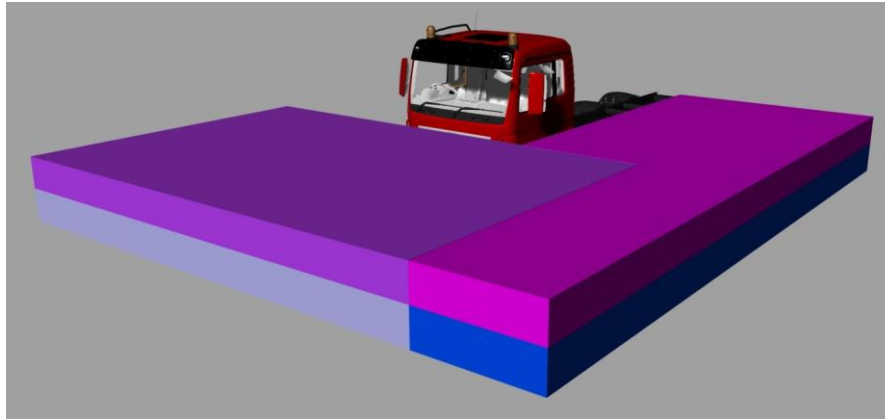
**Figure 4.2. N<sub>3</sub> rigid vehicle with side window – view of cyclist from rear**

Re-modelling the dashboard has the potential for similar improvements at the front of the vehicle without major structural change. Lower, on-road cabs give substantially greater improvement and the greatest improvement can be seen for the low entry cab.

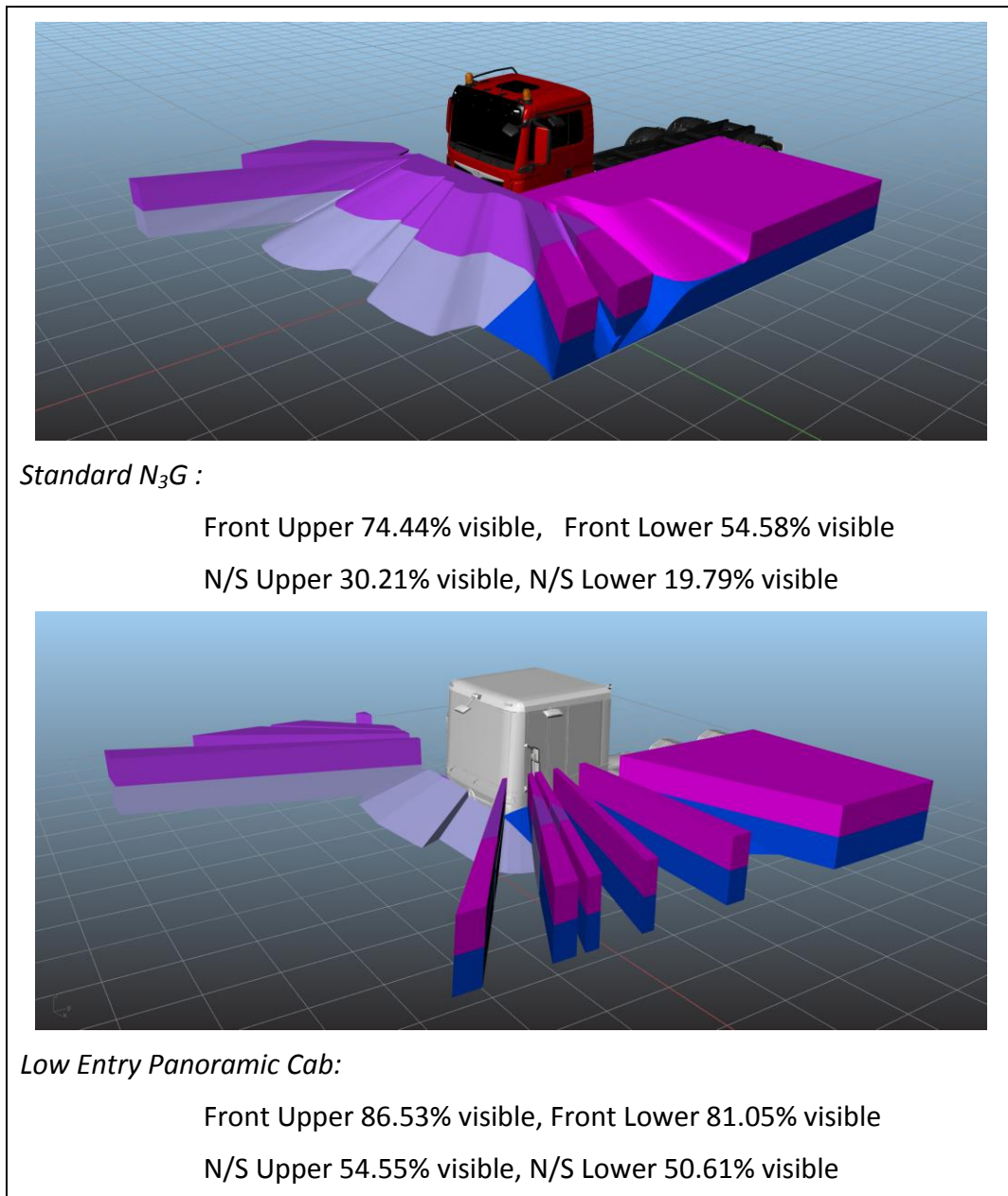
#### **4.1.1 Measuring the direct field of view**

The images above show the volume of space that is visible from the different vehicles. The previous section showed both the horizontal and vertical areas where vision was required to see vulnerable road users of different sizes, resulting in three-dimensional volumes of space where vision is required, as illustrated in Figure 4.3. Thus, the basic metric used to determine the vision performance is the proportion of the space within the area of greatest risk that can actually be seen from the vehicle.

Figure 4.4 shows a comparison of vehicles with the smallest and largest proportions of the assessment zones visible to the driver (note the coloured zones shown represent what is not visible to the driver). The standard N<sub>3</sub>G vehicle has a lower proportion of the assessment zone visible to the driver and there is a greater variation between the proportion of the upper zones visible when compared to the lower zones. The low entry panoramic cab has a higher proportion of each of the assessment zones visible, with less variation when the height of the assessment zone is considered.



**Figure 4.3. Front and nearside zones where direct vision is required.**



**Figure 4.4. Comparison of non-visible proportions of assessment zones.**



**4.1.2 Scoring the direct field of view.**

Each zone within the area of greatest risk (front/nearside, upper/lower) can have differing levels of importance. From the collision data it is known that, for London, the nearside zone is slightly more important than the front zone, so a weighting was applied to the percentage of each zone that was visible. The score for the nearside zone was considered to be worth 56% of the total mark and the front was 44%.

Similarly, consideration of the proportion of vulnerable road users that could be seen showed that the upper zone enabled a large adult male to be seen to the waist but only allowed head and shoulders of an average male to be seen and left a small female invisible. Therefore, the lower zone is of greater importance and was defined as contributing three times as much as the upper zone when calculating the overall scores. Sensitivity analyses were completed to assess the effect of the selected weighting and the collision data used on the outcome of the assessments. These analyses are described in Appendix C.

The relative importance of each zone can be expressed as a percentage as shown in Table 4.2.

**Table 4.2. Weightings applied to each assessment zone**

Front Upper	Front Lower	Nearside Upper	Nearside Lower
11%	33%	14%	42%

The final assessment score can be anywhere between 0 and 1 and varies continuously with changes to the geometry of the vehicle. Score boundaries (Table 4.3) have been selected such that the vehicle with least vision just fails to achieve one star and the vehicle with the best vision achieves five stars. The same score can be achieved by a variety of different designs, which leaves the manufacturers free to innovate and produce designs they think will both improve vision and meet other market needs. It should be noted that these scores are based on the vehicles that were assessed as part of this research project. Analysis of a wider range of vehicle types would allow the performance band to be validated further.

**Table 4.3. Definition of star rating boundaries in the Direct Vision Assessment Protocol**

Star rating	Rating boundaries
0 Stars	≥0 and ≤0.40
1 Star	>0.40 and ≤0.45
2 Stars	>0.45 and ≤0.50
3 Stars	>0.50 and ≤0.55
4 Stars	>0.55 and ≤0.60
5 Stars	>0.60 and ≤1.00

Converting the assessments of the vehicles shown above using this method of performance rating gives the results shown in Table 4.4 below.

**Table 4.4. Results from the application of the Direct Vision Assessment protocol<sup>5</sup>**

Star rating	Vehicle type assessed	Actual score
0 Stars	Standard N <sub>3</sub> G vehicles	0.39
1 star	N <sub>3</sub> G vehicle + single vision enhancement	0.41-0.42
2 stars	N <sub>3</sub> rigid vehicle baseline	0.46
	N <sub>3+</sub> single vision enhancement	0.49
3 stars	N <sub>3</sub> rigid vehicle + multiple vision enhancements <sup>6</sup>	0.52
	N <sub>3</sub> articulated vehicle	0.53
4 stars	None of vehicles assessed	N/A
5 stars	N <sub>3</sub> Low entry cab	0.65

It can be seen that the performance banding follows the expectation based on the earlier images of what could be seen from the vehicles but it is worth re-stating that it is not design dependant. The on-road specification vehicles achieve band B primarily because of their lower height. However, combining door window, dashboard re-modelling and some other small change may well be sufficient to enable the N<sub>3</sub>G vehicle to reach an ‘acceptable’ performance

The performance bands described above are intended to assess vision in the areas where vulnerable road users are most frequently killed by HGVs in low speed forward manoeuvring. It should be noted that some designs of low entry cab, which can have benefits in the sighting of vulnerable road users, employ several additional pillars for roof support and window and door division as illustrated in Figure 4.5.

These pillars do not have a substantial effect in terms of obscuring the view of vulnerable road users in close proximity because the blind spots remain small when close to the vehicle, particularly at the nearside where the angle that is obstructed is smaller. A person close to the vehicle is too big to hide in the resultant blind spot. However, the area obscured by the blind spot will grow as it gets further from the vehicle as illustrated in Figure 4.6 below, such that it might become relevant to interactions with cars and motorcycles when emerging from T-junctions or entering large roundabouts.

Unlike the blind spots caused by being too high, it is possible for the driver to eliminate these more distant blind spots simply by moving their head slightly. These low entry designs

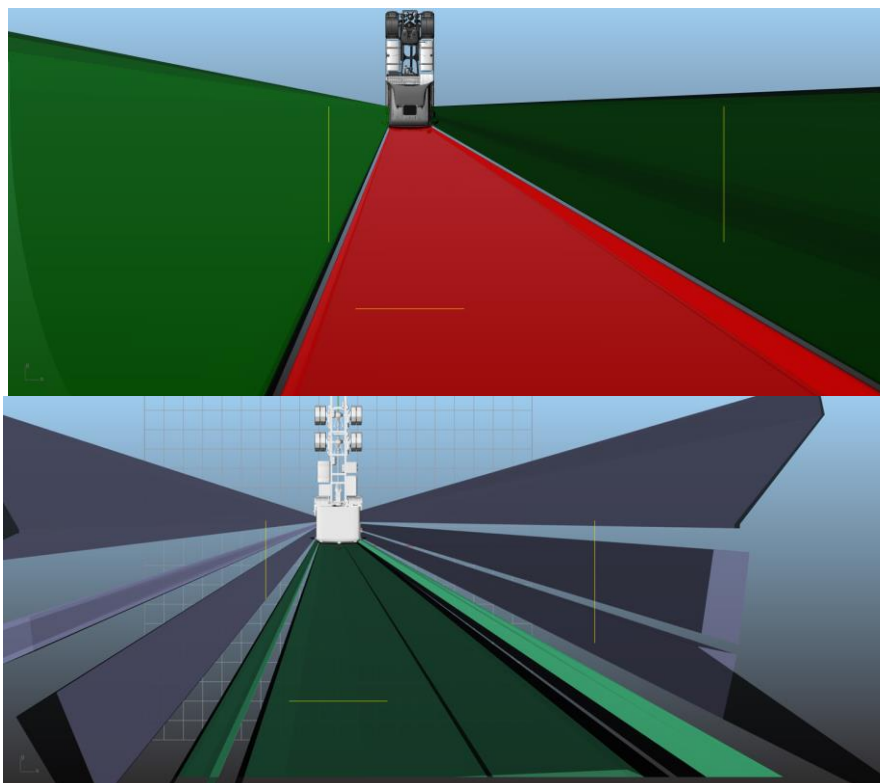
<sup>5</sup> It should be noted, assessments are made in an ‘as new’ condition. Dirt and clutter have the potential to degrade view in service and glass must remain clean and clear in service to remain effective.

<sup>6</sup> Estimate based on combing scores for additional side window and removed dashboard – not fully assessed.

have been in service for 10-15 years and there has not been any identified collision problems associated with this characteristic at this point in time. However, this represents a possible risk that should be monitored over time if the number of such vehicles increases in response to the introduction of this assessment. If problems are identified, then countermeasures can be introduced that would incentivise or mandate vehicles with fewer and/or smaller pillars.



**Figure 4.5. Highlighting pillars in low entry design.**



**Figure 4.6. Comparison of distant view between a standard articulated vehicle (top) and a low entry cab design (bottom).**

## 4.2 Options investigated

The following section summarises the assessment methods identified from the literature and the investigations/analysis completed during this project in order to define the Direct Vision Assessment Protocol.

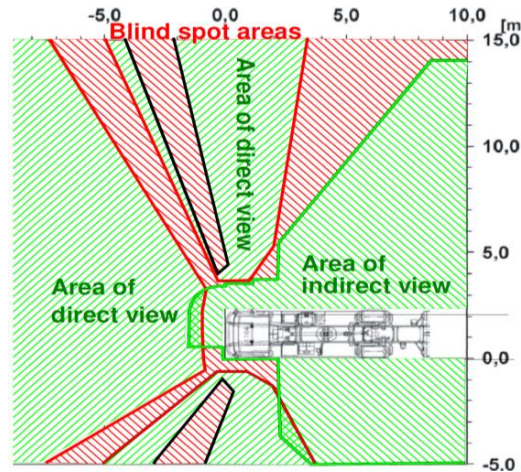
### 4.2.1 *Representation of the field of view*

#### 4.2.1.1 *Findings from the literature*

The review of standards and literature identified a range of different techniques for communicating the size of the visible area. This included projection onto horizontal or vertical planes, projections onto spherical surfaces and assessing the visibility of a matrix of vertical poles or cylinders around the vehicle. The methods are summarised in Table 4.5.

Table 4.5. Summary of methods identified for representing the field of view

Method	Advantages	Disadvantages
<p><b>Planar Projection</b></p> <p>Projection onto horizontal or vertical planes.</p> <p>Examples of this method can be found in UN Regulation 46 for indirect vision, SAE J1750 Horizontal Planar Projection method and the APROSYS Aggressivity index (shown right)</p> <p>The performance metric is usually the area that is or isn't visible</p>	<p>Relatively simple to achieve and easy to visualise.</p>	<p>Can be difficult to interpret from the measurement what the driver can actually see because the measurement does not show the height of an object that is visible.</p> <p>Although not the main focus of this research, it can also be difficult to represent visibility of a distant object. This can be overcome by the use of vertical planes, but can lead to distortions which need to be managed mathematically.</p>



**Two-dimensional assessment procedure, planar projection; based on direct and indirect vision projections onto horizontal planes 1.6 metres and 0.5 metres, respectively, above ground (APROSYS Heavy Vehicle Aggressivity Index) (Smith et al., 2008)**

Method	Advantages	Disadvantages
<p><b>Spherical Projection</b></p> <p>Projection onto the internal surface of a sphere.</p> <p>Developed for the PNCAP visibility protocol and used for the CLOCS/LDS-2015 window projection method.</p> <p>Performance metric is the area on the spherical surface that is or isn't visible. The surface is often restricted to the zone that is most relevant to the driving task.</p> <div data-bbox="562 284 1227 662"> </div> <p><b>Two-dimensional assessment procedure, spherical projection; direct vision from an example car projected onto a 10 metre sphere centred at the driver's eye point (PNCAP Visibility Protocol) (TRL, 2003)</b></p> <div data-bbox="562 863 1279 1177"> </div> <p><b>Visualisation of window areas projected onto a sphere centred on the driver's eye point, CLOCS/LDS-2015 Window Projection Method (Summerskill, Marshall, Paterson, &amp; Reed, 2015)</b></p>	<p>This method eliminates the distortion seen in the planar projection. The sphere is centred on the driver's eyepoint and so is always the same (or similar when considering head rotation) distance to the eyes. For any given improvement in visible angle, the same improvement in score is achieved, independent of where the improvement is made.</p>	<p>Can be difficult to visualise the result in terms of the proportion of a VRU that is visible at any given location.</p> <p>Centring the sphere at the driver's eye point means that there is no change in score associated with changing the height of the cab, which is critical when assessing close proximity field of view for HGVs. This can be overcome by restricting the assessment zone relative to the ground plane, although this will increase the complexity of the assessment.</p>

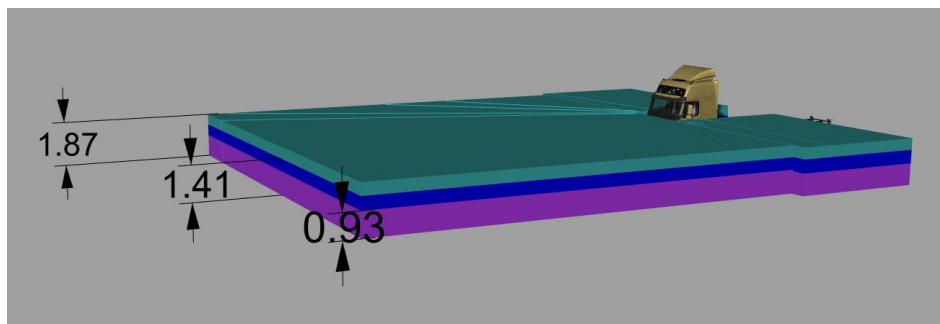
Method	Advantages	Disadvantages
<p><b>Target Evaluation Method</b></p> <p>Assessing the visibility of three dimensional targets positioned in a horizontal plane</p> <p>Examples of this method include</p> <p>CLOCS/TRL-2013 Visibility assessment method, CLOCS/LDS-2015 VRU analysis method, SAE J1750 Target Evaluation Method, UN Regulation No. 125, FMVSS 11, Japanese Safety Regulations Article 44 and NHTSA 2008 Rear Visibility Assessment</p> <div data-bbox="566 397 1285 756" data-label="Image"> </div> <p><b>Example of three-dimensional assessment procedure based on cylindrical target objects on a grid surrounding the vehicle</b></p>	<p>Immediate and intuitive interpretation of the visibility or obscuration of VRUs in close proximity to the vehicle.</p>	<p>In the absence of correction factors this method can distort the relative importance of the near and far fields of view.</p> <p>Assesses discrete points rather than the continuous volume around the vehicle</p>



From the methods identified, the target evaluation method was selected for further investigation and development for the Direct Vision Standard.

In all of the approaches that assess the ability to see specific targets, the visibility targets are spread out across the ground (or moved around), thus assessing discrete points rather than a continuous volume. The spacing of the targets therefore determines the resolution of the measurement method. With the suggested CAD-based assessment it is possible to model even small vehicle design changes, the effect of which on the field of view might fall in between two of the targets and not be rewarded appropriately in the assessment. Additionally, SAE J1750 calculates the volume of each individual cylinder that can be seen and for each 'layer' of the cylinder, requiring a large number of calculations.

The visibility targets can be considered merely as a way of approximating an entire three-dimensional volume. This volume can also be divided into vertical layers (as used in SAE J1750) as shown in Figure 4.7, below.



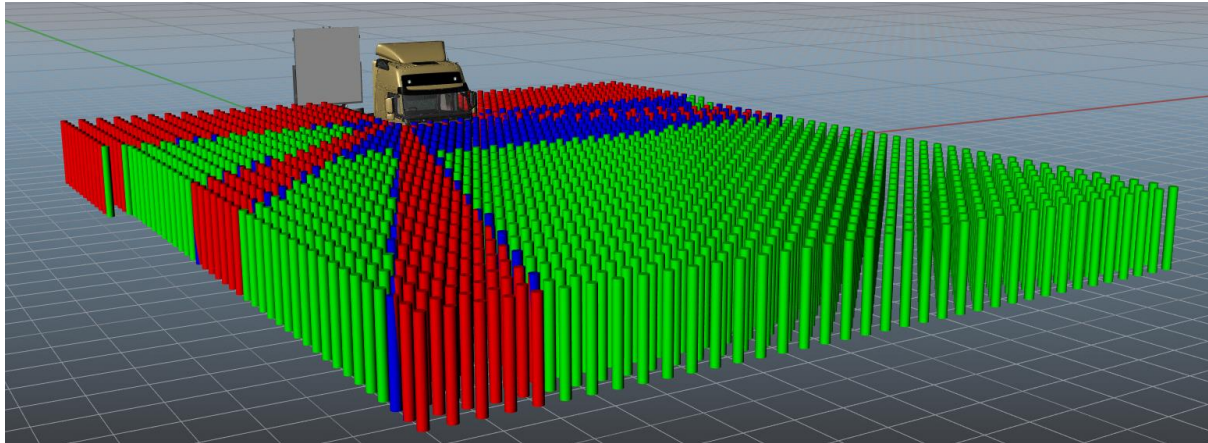
**Figure 4.7: Three-layered continuous volumes surrounding the vehicle used as the visibility target. The heights of the layers (in metres) are based on heights of vulnerable road users.**

Calculating the volume of each layer would provide theoretically perfect resolution and could be completed with fewer calculations.

#### 4.2.1.2 Comparing target cylinder and volumetric methods

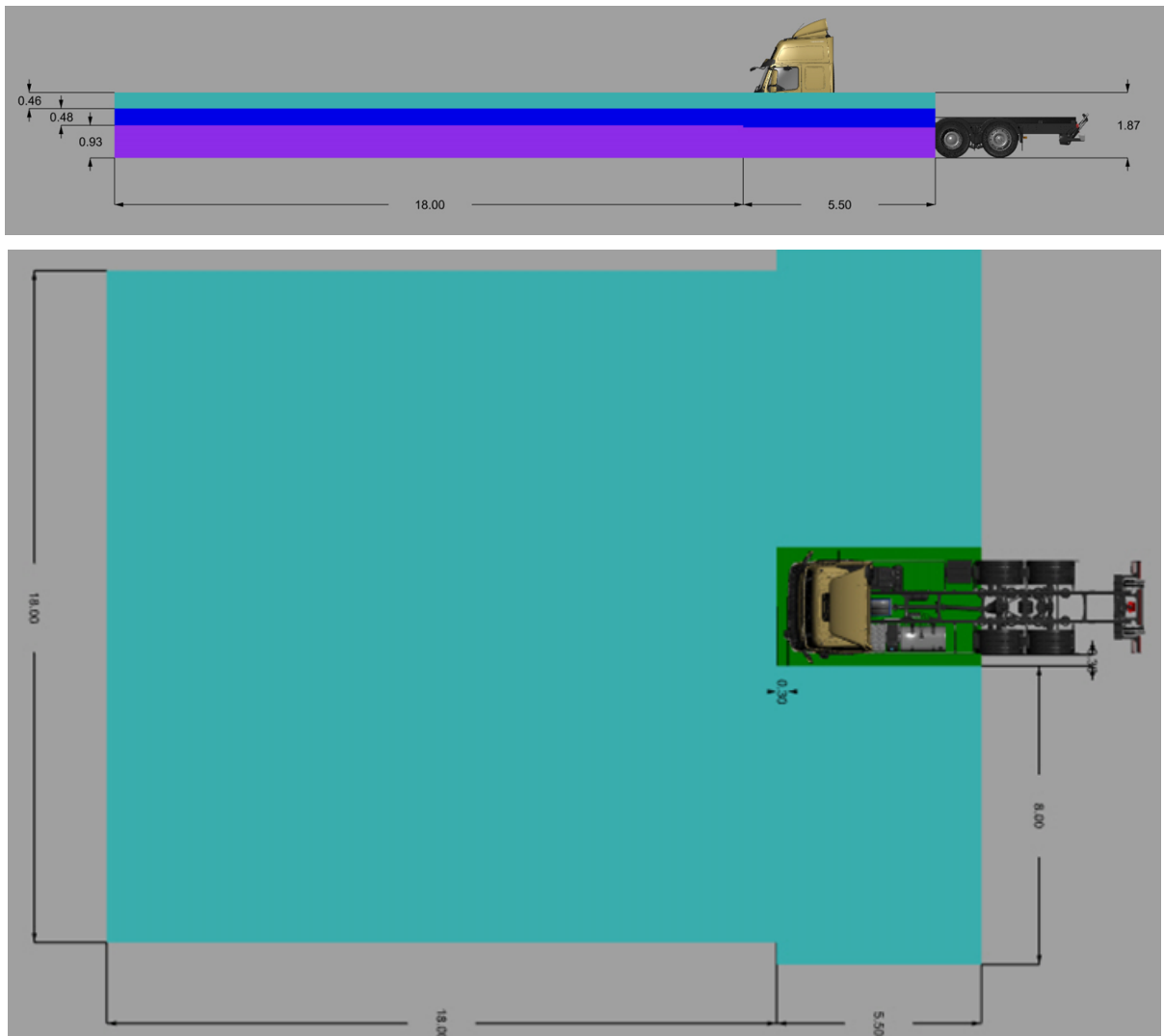
The results achieved using a visibility target technique, similar to SAE J1750, and a volumetric technique were evaluated by assessing an N<sub>3</sub> on-road HGV, based on a commercially sourced model. Figure 4.8 shows an initial representation of the output from the target assessment method. The green cylinders represent the target cylinders that were 100% visible and red cylinders those that were outside the field of view and could not be seen. Cylinders shaded blue are partially visible to some extent, with blue representing the visible portion. For the blue cylinders in front of the vehicle, the top part will be visible and the bottom part not. Whereas, the blue cylinders bounding the a-pillar obscured zone will be visible for the total height, but not the full diameter. For each cylinder, the proportion of the volume visible was calculated. However, this method (in this format) does not differentiate between which part of the VRU would be visible and a further development would be to define vertical limits as described in SAE J1750.



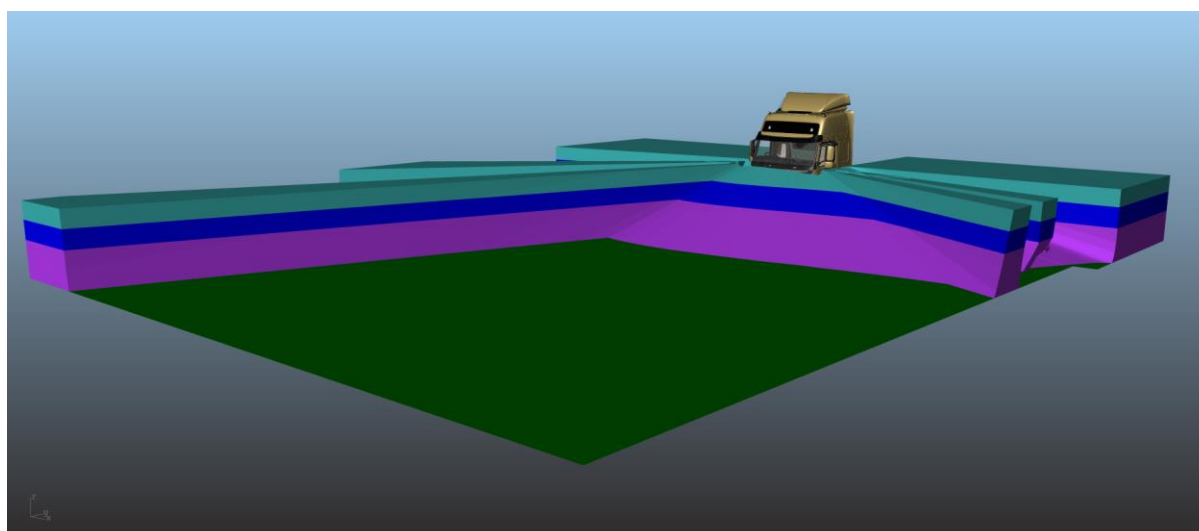


**Figure 4.8. 3D representation of target (cylinder assessment method)**

The equivalent volumes assessed in the volumetric calculations are shown in Figure 4.9 , below. The outer dimensions were the same as those used for the target evaluation method. Figure 4.10 shows an example of the volume that can't be seen from this vehicle.



**Figure 4.9. Volume assessment zones**



**Figure 4.10. Example of the volume that can't be seen by the driver.**

Comparison between the visible areas generated by the cylinders and assessment volumes are shown in Table 4.6. There was broad correlation between the cylinder target method and the volumetric method. A difference between the methods would be expected because the volume method allows for every small geometric characteristic of the vehicle to be assessed, which may be missed in the cylinder method. The cylinder target method showed a higher proportion visible for the nearside and front, whereas there was a lower proportion visible to the offside. This is most likely attributed to the position of the driver's eye relative to the window and the angle of the sightlines generated.

**Table 4.6. Comparison of cylinder target and volumetric assessment**

	% Visible	
	Cylinder Target	Volumetric
Nearside	16%	13%
Front	84%	82%
Offside	14%	17%

**4.2.2 Reviewing the assessment method**

The assessment method used needs to be sensitive enough to differentiate between the vehicles and ensure that changes in vehicle design that improve the close proximity direct field of view in the required areas are suitably rewarded.

The initial analysis considered an extended assessment zone to ensure that all aspects of direct vision were captured in the assessment protocol. The literature relating to existing standards highlighted the distortions that projections onto a plane could introduce in terms of the value of near and far fields of view. The focus of this research is the area in close proximity to the HGV, therefore, a modelling exercise was undertaken to investigate the use of different sized assessment areas to minimise the impact of any distortions. The effect of the weightings that would be applied to each assessment zone

was also tested. The results were expressed in terms of a derived visibility score for the six virtual vehicles previously described in Table 4.4.

The zones considered in the analysis were a nearside and frontal 'priority zone' based on the areas of greatest risk and wider frontal, nearside and offside zones. Two sizes were considered for the wider frontal zone 10m long and 18m long. The wider side zones extended to 8m either side of the vehicle. Each zone was divided into the same three layers defined previously.

The weighting schemes considered were fundamentally based on the distribution of accident types as identified earlier in Table 3.1 for London. However, consideration was given to 12 different weighting schemes that ranged from including only the priority zones, inclusion/exclusion of the offside zone, differing importance of the vertical zones and equal weighting of all zones. Full details can be seen in Appendix C. The results were based on calculations of visible volume in each zone and can be seen in Table 4.7 and Table 4.8.

**Table 4.7. Results with an 18m extended frontal zone**

	<b>N<sub>3</sub>G</b>	<b>N<sub>3</sub>G low window</b>	<b>N<sub>3</sub>G no dash</b>	<b>N<sub>3</sub> rigid</b>	<b>Low cab</b>
Weighting #1	0.40	0.42	0.41	0.43	0.61
Weighting #2	0.31	0.33	0.34	0.39	0.59
Weighting #3	0.37	0.38	0.38	0.38	0.58
Weighting #4	0.37	0.38	0.38	0.39	0.59
Weighting #5	0.38	0.39	0.39	0.40	0.59
Weighting #6	0.38	0.40	0.40	0.40	0.59
Weighting #7	0.39	0.41	0.40	0.39	0.58
Weighting #8	0.39	0.41	0.41	0.42	0.60
Weighting #9	0.39	0.41	0.41	0.42	0.60
Weighting #10	0.34	0.36	0.37	0.40	0.60
Weighting #11	0.35	0.37	0.38	0.41	0.60
Weighting #12	0.36	0.37	0.38	0.41	0.60

**Table 4.8. Results with a 10m extended frontal zone**

	<b>N<sub>3</sub>G</b>	<b>N<sub>3</sub>G low window</b>	<b>N<sub>3</sub>G no dash</b>	<b>N<sub>3</sub> rigid</b>	<b>Low cab</b>
Weighting #1	0.37	0.42	0.39	0.42	0.59
Weighting #2	0.31	0.33	0.34	0.39	0.59
Weighting #3	0.35	0.38	0.37	0.37	0.56
Weighting #4	0.35	0.38	0.37	0.38	0.57
Weighting #5	0.37	0.39	0.38	0.39	0.58
Weighting #6	0.37	0.39	0.38	0.39	0.58
Weighting #7	0.37	0.40	0.38	0.38	0.56
Weighting #8	0.38	0.42	0.40	0.42	0.59
Weighting #9	0.36	0.39	0.38	0.41	0.59
Weighting #10	0.33	0.36	0.36	0.40	0.59
Weighting #11	0.34	0.37	0.37	0.41	0.59
Weighting #12	0.34	0.37	0.37	0.39	0.58

It can be seen that all methods show the low entry cab as the highest ranked and the standard N<sub>3</sub> cab is the lowest. However, the degree to which they discriminate between the small modifications to the lowest ranked vehicle and a mid-range vehicle do vary somewhat.

Given the London weighting identifying nearside vision as slightly more important than vision to the front, the expected progression would be improvement from left to right in the tables and you would expect the improvements to be graduated and measurable.

Weighting scheme numbers 2 and 10 to 12 with the 18m frontal zone conform to that expectation most closely, though it should be noted that weighting number 2 gives zero weight to every area except the 'priority' close proximity zones (hence the same results in both tables). Thus, if weighting 2 was selected, consideration may be required if potential unintended consequences on the unmeasured areas are to be avoided. Weightings number 10 to 12 all give very low weights to the extended zones so provide only weak disincentive to unintended consequences outside of the close proximity nearside and frontal zones.

There appears to be minimal effect of changing the broader assessment volumes from 18m to 10m. The benefit of assessing such a wide zone is questionable and therefore an assessment based only on the close proximity zones (weighting #2) has been taken forward to develop the assessment protocol.

## 5 Measuring the view

Based on the information identified from the review of standards and test methods, Table 5.1 was generated to summarise the potential approaches that could be used for measuring (rather than assessing) the field of view. The matrix categorised the possible approaches for the key features of a technical standard with respect to the procedural complexity and procedural fidelity.

Each combination of procedural fidelity and complexity from the matrix in Table 5.1 was scored against the criteria in Table 5.2. The weightings that were applied identified the most relevant criteria with a score of 1. Accessibility and cost were considered to be closely linked and the weighting score of 1 was split between the two criteria. Two independent assessments were completed, with the rank order of concepts being the same for both assessments. The average results are shown in Table 5.3.

**Table 5.1. Matrix of measurement possibilities based on review of literature**

Procedural Complexity	Procedural Fidelity		
	Simplified	Moderate	Representative
<b>Accessible</b> (Physically measure view)	<ul style="list-style-type: none"> <li>No accuracy/resolution requirements</li> <li>Most popular vehicle specification</li> <li>Manufacturer recommendations for vehicle set-up</li> <li>Cyclopean monocular viewpoint</li> <li>Single defined viewpoint location – 50<sup>th</sup> percentile</li> </ul>	<ul style="list-style-type: none"> <li>No accuracy/resolution requirements</li> <li>3 model variants, worst, best and best selling</li> <li>Manufacturer recommendations for vehicle set-up</li> <li>Cyclopean monocular viewpoint</li> <li>5<sup>th</sup>/95<sup>th</sup> percentile viewpoint definitions</li> </ul>	<ul style="list-style-type: none"> <li>No accuracy/resolution requirements</li> <li>All vehicle specifications</li> <li>Predefined vehicle set-up; 5<sup>th</sup>/95<sup>th</sup> %ile steering wheel and seat positioning defined based on Reed (2005) algorithms</li> <li>Binocular/ambinocular viewpoints</li> <li>Full eyellipsoid defined viewpoint location range based on Reed (2005) algorithms</li> </ul>
<b>Technical – prescriptive</b> (Laser scan vehicle, project view in CAD)	<ul style="list-style-type: none"> <li>Min. accuracy/resolution requirements</li> <li>Most popular vehicle specification</li> <li>Manufacturer recommendations for vehicle set-up</li> <li>Cyclopean monocular viewpoint</li> <li>Single defined viewpoint location – 50<sup>th</sup> percentile</li> </ul>	<ul style="list-style-type: none"> <li>Min. accuracy/resolution requirements</li> <li>3 model variants, worst, best and best selling</li> <li>Manufacturer recommendations for vehicle set-up</li> <li>Cyclopean monocular viewpoint</li> <li>5<sup>th</sup>/95<sup>th</sup> percentile viewpoint definitions</li> </ul>	<ul style="list-style-type: none"> <li>Min. accuracy/resolution requirements</li> <li>All vehicle specifications</li> <li>Predefined vehicle set-up; 5<sup>th</sup>/95<sup>th</sup> %ile steering wheel and seat positioning defined based on Reed (2005) algorithms</li> <li>Binocular/ambinocular viewpoints</li> <li>Full eyellipsoid defined viewpoint location range based on Reed (2005) algorithms</li> </ul>
<b>Technical – flexible</b> (Define CAD projection but source of CAD model open)	<ul style="list-style-type: none"> <li>Min. accuracy/resolution requirements</li> <li>Most popular vehicle specification</li> <li>Manufacturer recommendations for vehicle set-up</li> <li>Cyclopean monocular viewpoint</li> <li>Single defined viewpoint location – 50<sup>th</sup> percentile</li> </ul>	<ul style="list-style-type: none"> <li>Min. accuracy/resolution requirements</li> <li>3 model variants, worst, best and best selling</li> <li>Manufacturer recommendations for vehicle set-up</li> <li>Cyclopean monocular viewpoint</li> <li>5<sup>th</sup>/95<sup>th</sup> percentile viewpoint definitions</li> </ul>	<ul style="list-style-type: none"> <li>Min. accuracy/resolution requirements</li> <li>All vehicle specifications</li> <li>Predefined vehicle set-up; 5<sup>th</sup>/95<sup>th</sup> %ile steering wheel and seat positioning defined based on Reed (2005) algorithms</li> <li>Binocular/ambinocular viewpoints</li> <li>Full eyellipsoid defined viewpoint location range based on Reed (2005) algorithms</li> </ul>

**Table 5.2. Scoring criteria for concept evaluation**

Evaluation Criteria	Score definition		Weighting
	1	5	
<b>Representativeness</b>	Simplified to the point of allowing significant variance between test score and what a real driver can actually see	Fully representative of real human vision of a wide range of driver sizes	1
<b>Repeatability &amp; Reproducibility</b>	Few controls on measurement accuracy, substantial subjectivity	Accurate objective measures with extensive control of non-evaluated variables	1
<b>Accessibility</b>	Requires expensive or complex equipment or facilities or rare specialised knowledge or expertise	Can be undertaken without specialist equipment by non-technical personnel	0.4
<b>Flexibility</b>	Inflexible, any small change in vehicle specification or procedure requires complete re-measurement. Prescriptive on methods/equipment	Once measurements are made, a wide range of assessments including altered vehicle specification can be undertaken in software. Open to different methods/equipment	0.4
<b>Independence</b>	Relies solely on information provided by significant vested interest	Undertaken entirely independently without input from any vested interest	0.4
<b>Cost</b>	Most Expensive	Cheapest	0.6

**Table 5.3. Average results of concept evaluations**

		Procedural Fidelity		
		Simplified	Moderate	Representative
Procedural Complexity	Accessible	13.1	13.4	13.9
	Technical – Prescriptive	13.3	13.6	14.9
	Technical - Flexible	14.2	14.5	15.8

The evaluation described above provided a clear indication that the TfL Direct Vision Assessment Protocol should aim to be the most representative possible using a technical but flexible procedure. All vehicle manufacturers who responded to the consultation supported using the technical, CAD based, approach and most agreed the exact method should be flexible. However, most manufacturers preferred a simplified approach in terms of procedural fidelity; though several offering that view stated that they would defer to technical specialists in central research and development departments overseas. Adopting the most fidelic approach is justified by the literature and the objective analysis of options. Vehicle manufacturers are one of the stakeholders that might lose out because of some of the disadvantages of a simplified approach. For example, if the simplification unfairly penalised their vehicle over a competitors. Thus, simplification of the process could be considered in future if the industry maintains a preference for it after a period of deeper analysis.

## 5.1 Proposed measurement method

The TfL Direct Vision Assessment Protocol defines a method for measuring the direct field of view from HGVs. The method is based on the standards and literature reviewed and the field of view modelling that has been completed. The following aspects of the measurement have been considered and defined.

**Use of a digital vehicle model** - Manufacturer-provided CAD models should be used where available and a method has been provided for verifying the performance of production vehicles against the ratings reported. To ensure repeatable methods are used, guidance is provided for generating 3D CAD models of vehicles where they are required.



**Figure 5-1. Example vehicle model – Mercedes Econic**

**Vehicle setup** – Several items that affect the field of view can be adjusted by the driver or operator, for example suspension settings, tyre pressures, fuel load, cargo carried etc. Wherever possible, the position or setting that the measurements should be taken in has been defined as the one that is considered likely to represent the most common usage on



the road. Where this was not possible, the protocol will require the position or setting that most restricts the field of view, which represents a worst case.

**Vision point** – The vision point is the position of the eyes from which the view will be assessed. In defining this, it is possible to consider different sizes of driver with different preferences for seat positioning, and different ways of looking (move eyes, rotate head, rotate from waist). It is also possible to consider different approaches to calculating the area visible. For example, you could measure the view from one eye only (monocular), you could count only the view that is visible to both eyes (binocular) or you could consider an area that is visible to at least one eye (ambinocular). The protocol aimed to strike the optimum balance between accurately representing how real humans see and the complexity and effort required for the assessment.

As such, the protocol is based on calculating the volume that can be seen by at least one of the two eyes (ambinocular vision) of a 50<sup>th</sup> percentile UK male driver, including rotation of the head but not the torso. The driver seating position (which can affect the vision point) is also defined based on an independent and objective seat positioning process developed in the USA, but adapted to use driver sizes based on the UK population. In this way, the measurement process is reasonably representative of the real world but is also repeatable and reproducible with manageable effort.

**Visual obstructions** - Items identified as visual obstructions, for example vehicle fascia, steering wheel, passenger seat, etc. are controlled for in the CAD based evaluation. Where applicable, a representative approach for adjusting the majority of these items has been proposed. For example, by positioning the passenger seat half way between its foremost and rearmost positions and keeping it unoccupied, windscreen wipers in resting position, sun visors and blinds stowed away. For some of the items, such as armrests, passenger seat head restraint and any other equipment not explicitly mentioned, the worst-case adjustment (i.e. maximum obscuration) has been chosen because the most common adjustment position is unknown. For the mirror housings a worst case approach is also proposed because the adjustment preferences between drivers can vary widely and no appropriate research was identified for repeatable, average driver-specific adjustment positions. The steering wheel is positioned using a similar approach to that used for the driver’s seat. Criteria for defining semi-transparent items are also specified.

## 5.2 Measurement options investigated

### 5.2.1 Measurement philosophy

There were two different general approaches used in the regulations and standards reviewed for measuring visibility: Measuring directly the view from a vehicle under certain conditions or measuring the vehicle to create a digital model that allows a subsequent assessment of the available view.

- Regulations and older standards largely prescribe methods for directly measuring the view, for example; by moving a target object around the vehicle while a driver of

appropriate size assesses its visibility (Japanese Safety Regulations Article 44, NHTSA 2008 Rear Visibility Assessment),

- by placing a camera at an average driver's eye location and assessing whether defined points on the ground are visible (FMVSS 111), or
- by using light sources placed at the driver's eye locations and noting the boundaries of the lit areas around the vehicle (UN Regulation No. 46).

The alternative method of first creating a digital vehicle model and subsequently assessing the view via computer-based calculations is employed in the CLOCS/LDS-2015 VRU Analysis Method, and the SAE J1750 Target Evaluation Method. The reason this approach was not used in the past may lie in the requirement for computer support which is now more readily available.

The advantages of measuring the view directly are the simplicity and the reduced measurement equipment requirements. Measuring and digitising the vehicle is more complex and requires moderately sophisticated measurement hardware (typically a laser scanner although it could be a 3D coordinate measuring arm or equivalent) combined with appropriate software. It can be difficult to establish methods without prescribing one particular measurement system over another. However, the scanning itself is relatively quick and does not require much space and the measurement only needs to be done once for a given cab design and interior structure.

Advantages of measuring the vehicle are that it allows an intuitive visualisation of three-dimensional visual obscuration and that it affords greater flexibility: Changes in eye position, cab mounting height, changing in-cab equipment or even modest changes to window or door apertures can be assessed purely in software with no further measurement.

Moreover, vehicle manufacturers will most often have CAD models available that can be used for the assessment, which has the potential to eliminate the effort of measurement entirely.

### **5.2.2 Digitisation techniques**

If virtual assessment is considered and a manufacturer CAD model does not exist (or for compliance tests), it is necessary to create a digital 3D model from a production vehicle. It is worth considering whether a specific technology needs to be prescribed for creating this model.

The common technologies available for digitising vehicles are 3D coordinate measuring arms or 3D coordinate laser scanners. When applied correctly, both technologies can achieve results of similar quality. It appears that use of laser scanners is becoming more widespread in recent years, e.g. (Teizer et al., 2010) and many specific criminal or civil accident investigations, likely because of the decrease in equipment costs in recent years and higher convenience in use.

Both technologies are used in the standards and reports reviewed for this project: The PNCAP Visibility Protocol (from the year 2003) is defined mainly for the use of a measuring arm. The CLOCS/LDS-2015 assessments used laser scanners.

None of the standards reviewed specified in quantitative terms the required accuracy of the vehicle 3D model or of the final measurement or calculation of view. It is likely that this is because there is no perfectly accurate benchmark of such a measure against which to compare or calibrate the test result. However, the research suggests that relatively small differences in critical areas such as eye-position or height of the lower edge of the nearside passenger door window could have a significant effect on the results of an assessment (Summerskill, Marshall, Paterson, & Reed, 2015). Therefore, some control of accuracy of the manufacturer-provided CAD model or the 3D-scanning equipment used to obtain the model is required to ensure the assessment results are reliable and reproducible.

The passenger car direct vision standard developed in the DfT funded PNCAP project (TRL, 2003) and the counter proposal from industry (ACEA, JAMA, KAMA, 2004) specified methods of identifying the eye point which, although not verifiable, were designed to control variation in the position. In addition to this, it was specified that the vehicle dimensions must be digitised with an accuracy of  $\pm 2$  mm. Similarly, the resolution was specified such that corners or acute angles in the vehicle structure must be measured every 2 mm, other components every 5 mm. That resolution could be decreased to measurements every 50 mm on fundamentally straight edges (curvatures of less than  $1^\circ$ ).

No formal definition of requirements was identified for a laser scan process. TRL has developed a procedural description for use in its accident investigation activities. This contains information on the test equipment and conditions required, and provides instructions for setting up the vehicle and performing the visibility scans and post-processing of the data. The procedure recommends a series of seven laser scans from different positions inside and outside of the cab, and subsequent combination of the scan data into one 3D point cloud model. Subsequently, a 3D surface model (CAD model) may be created from this data, which improves handling of the model in software. This is an optional step, however, because the field of view can also be evaluated and assessed directly from the point cloud model. Instructions are attached to the Direct Vision Standard as informative Annex C, Vehicle 3D-scanning procedure.

The minimum requirements for equipment regarding accuracy and resolution of the laser scanner were based on the minimum model accuracy required for evaluation and assessment part of the Direct Vision Protocol. It was verified that common scanners on the market can achieve these values, for instance FARO Focus 3D or RIEGL VZ models.

Restrictive prescriptions of test conditions (such as indoor conditions or a narrow temperature range) are not required for this procedure, because laser scanners are commonly specified for use in indoor and outdoor conditions and in a wide temperature range. Moreover, some scanner models use GPS signals, which is why outdoor conditions may even be advantageous. Rainy conditions need to be avoided because rain drops reflect the laser beams which would increase noise in the model or render the scan unusable.

Seven laser scans are recommended as a minimum number (from five positions outside and two positions inside the cab). Based on experience from TRL's HGV scanning and the CLOCS/LDS-2015 work, this number allows the relevant features of the cab to be captured with sufficient detail for the direct vision application. The time required for a laser scan is highly dependent on the equipment and the chosen resolution. Using a typical laser scanner,

---

such as a FARO Focus 3D, the required scan quality will be achievable with a duration of 30 minutes or less per scan

### **5.2.3 Control of vehicle factors affecting cab height – vehicle setup**

There is a strong correlation between the height of the vehicle cab over ground and the extent of the direct vision blind spots. A larger cab height correlates to a larger driver eye height above ground, which leads to an increase of the obscured volume around the vehicle. This means that, assuming other design features are kept constant, higher cabs tend to be at a disadvantage for direct vision in close proximity to the HGV. Research on existing vehicles found a strong positive correlation between these factors (Summerskill, Marshall, Paterson, & Reed, 2015). The cab height of a vehicle is variable, with factors such as tyre pressure or load, and in some cases adjustable via air suspension. Cab height is therefore an essential factor that needs to be controlled to ensure a representative, repeatable and reproducible evaluation can be provided.

The review of existing standards yielded the following list of parameters that are controlled in at least one of the standards:

- Suspension positioning
- Vehicle tyre pressure
- Fuel level
- Level of other fluids (lubricants, coolants, etc.)
- Ballast from driver, passenger, luggage and payload

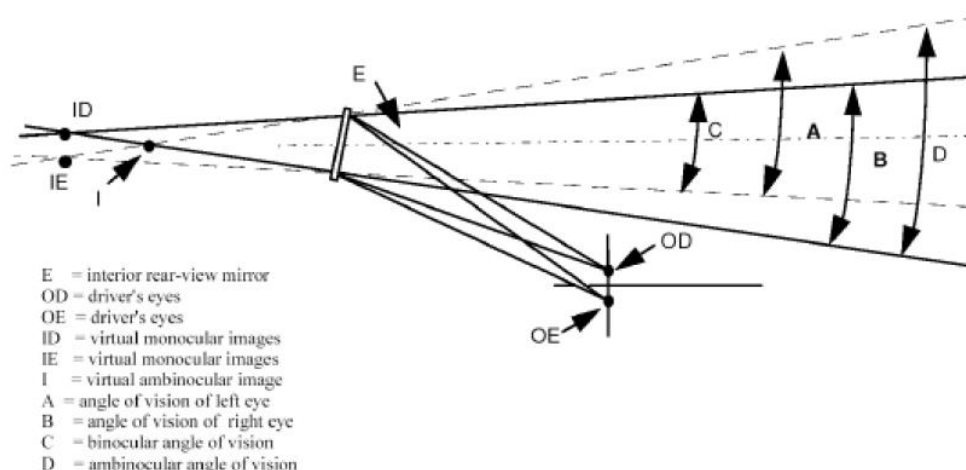
The exact effect of variations in these parameters was not identified in the literature. However, theory would suggest that the effect of fluid levels and driver ballast would be low because the masses involved are very small relative to the mass of the payload and the non-variable parts of the vehicle itself. However, substantially reduced tyre pressure and suspension positioning could easily make larger differences of more than 10 cm.

### **5.2.4 Representing diversity in driver size**

It is necessary to define where the eye points of the driver shall be located for the assessment procedure in relation to the seat (or a fixed vehicle point) for a given driver stature. The aim is to define points or areas representative of how drivers position themselves in real driving conditions. Driver eye point positioning is therefore highly specific to the vehicle type, primarily because of geometric differences of vehicle controls (such as the steering wheel position) and driver size. Drivers vary widely and it is, therefore, impossible to accurately model the view for every individual. Some form of simplification is inevitably required but can vary in its degree. Three methods for positioning the driver eye points were identified from the articles reviewed in this project, including the:

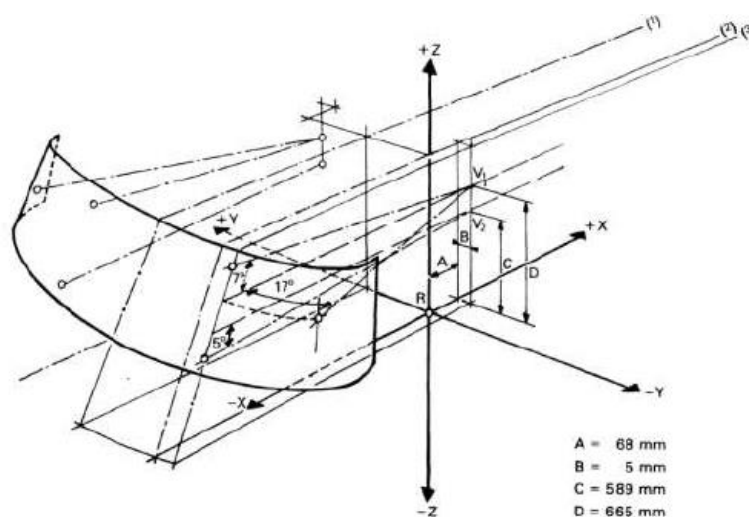
- Single defined position technique (e.g. 50<sup>th</sup> percentile male)
- Multiple defined position technique (e.g. 5<sup>th</sup> %ile female and 95<sup>th</sup> percentile male)
- Eyellipse technique.

The single position technique was primarily adopted by procedures that used monocular eye points (e.g. PNCAP, SAE J1750). Using fixed position, forward facing, eye points to create a field of view for ambinocular vision, UNECE Regulation 46 evaluated the extent of indirect visibility available to the driver of the vehicle through the interior and exterior mirrors from a single location (Figure 5.1).



**Figure 5.1. Indirect fields of vision from single fixed position eye points, as calculated by UN Regulation 46 (UN Regulation 46, 2014)**

The multiple eye point location technique was adopted by several other procedures, with UN Regulation 125 perhaps the most notable example. These typically defined eye point locations at the 5<sup>th</sup> and 95<sup>th</sup> percentile eye point positions for a specific population. UN Regulation 125 stipulates direct vision requirements from two specific monocular viewpoints located at positions representing the mid-eye point of 5<sup>th</sup> and 95<sup>th</sup> percentile passenger car drivers. These methods provide discreet assessment locations where the direct visibility of the driver can be evaluated. Although potentially a strong technique for analysing the visibility around specific obstructions, the discreet nature of such a method could provide a perverse incentive to manufacturers when positioning key structures such as the A and B-pillars.

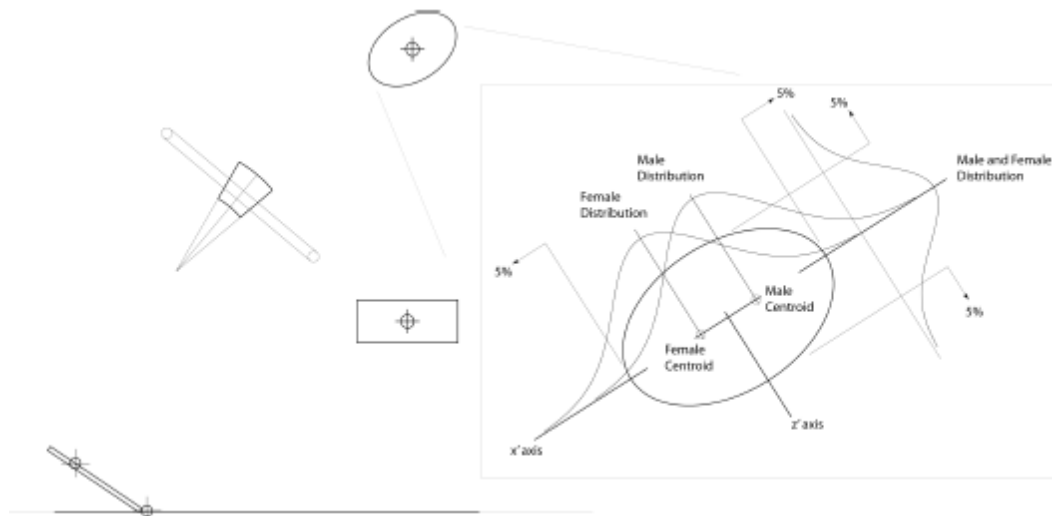


- (1) Line tracing the median longitudinal plane of the vehicle.
- (2) Line tracing the vertical plane passing through R.
- (3) Line tracing the vertical plane passing through V<sub>1</sub> and V<sub>2</sub>.

**Figure 5.2. UN Regulation 125 V points (V1/V2) located at the 5<sup>th</sup> and 95<sup>th</sup> percentile driver eye point locations (UN Regulation 125, 2013)**

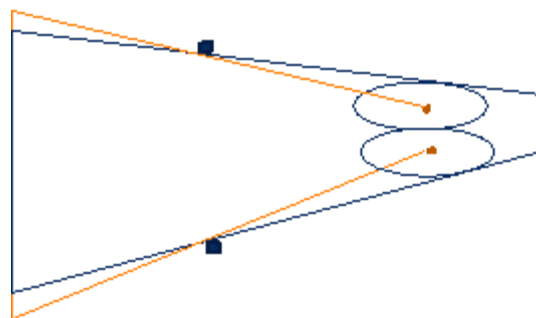
Finally, the eyellipse (a contraction of the word eye and ellipse) technique describes the elliptical statistical distribution of driver eye locations in three-dimensional space located relative to defined vehicle reference points. SAE J941 and SAE J1050 contain a model defining the eyellipses for both passenger cars and HGVs (Class-B vehicles); however, as the model has not been updated since 1987, it remains outdated. Reed (2005) recently updated the eyellipse model to account for modern HGV designs, with highly adjustable seating and steering wheel positions.

Reed (2005) describes the dimensions of the eyellipses for each eye and their location in respect to the accelerator heel point (AHP) of the vehicle (Figure 5.3). Necessary inputs for the model include the driver stature and steering wheel position to generate vehicle and population specific eyellipses. These eyellipses can be calculated to create field of view lines, at a tangent to the eyellipse surface, that represent the minimum field of view that would be visible to a particular percentage of the HGV driver population.



**Figure 5.3. Schematic of HGV driver eyellipse construction (Reed M. P., 2005)**

The eyellipse has the benefit that it allows for a population of drivers to be considered during the analysis, however this type of viewpoint is more difficult to implement in both a physical testing environment and a virtual environment. While a defined view point (rather than eyellipse) is easier to implement in a physical environment, the position is only representative of a single driver stature. The potential effect of using one or other of these viewpoints on the horizontal field of view is shown in Figure 5.4. The area visible to the eyellipse is much smaller than that generated using the eye point technique because it is representing only the view that can be seen by all sized drivers within the defined range.



**Figure 5.4. Plan view schematic of ambinocular vision fields of view for the eyellipse (blue) and eye point (orange) viewpoint positioning procedures**

**5.2.5 Biofidelity of the representation of human vision**

*5.2.5.1 Findings in the literature*

Three common vision types (monocular, binocular and ambinocular vision) were adopted by the reviewed articles to establish the direct field of view of the HGV driver. Monocular vision was defined as the field of view from a single eye point position (i.e. either the left or right eye point or a cyclopean eye point situated at the centre-point of the two eyes). Binocular



vision was defined as the direct field of view seen simultaneously by both the left and right eye points and was defined by establishing the common area shared by the left and right eye monocular fields of view. Finally, ambinoocular vision was defined as the direct field of view as seen by at least one of two eyes and was defined by combining the areas shared by the left and right eye monocular fields of view.

Using ambinoocular vision to assess direct vision allows a greater field of view to be seen than monocular vision, whilst binocular vision is also particularly relevant for considering maximum visibility around narrow visual obstructions such as A-pillars and mirrors. Further consideration of the most appropriate eyepoints is described in section 5.2.5.2.

It is important to note that the ambinoocular method was employed by all indirect visibility assessment procedures reviewed by this study. This was due to it being the only method that truly represents the full area of visibility shown in a mirror and is accepted by both EU and US regulations and standards (see Figure 5.1). This is an important consideration if there are any future plans to integrate the assessment protocol in another application.

A technique that rotates the eye points about a specified neck pivot point, representing the turning of the head by the neck, was adopted by several reviewed procedures. All US regulations and standards (FMVSS104, FMVSS111, SAE J1050 and SAE J1750) used this approach alongside the Japanese Regulation (Japanese Safety Regulations Article 44) and all ISO standards (ISO 5006, ISO 7397 and ISO 14401). By locating the eye points and neck pivot points at physically representative positions, these techniques all allowed the eye points to be rotated about the neck pivot point to face the point of interest, thus providing the most representative technique for positioning the eye points. Although a number of procedures were adopted for positioning the eye and neck pivot points, only Reed (2005) specified these positions based on HGV driver anthropometry.

Two methods of aligning the eyes to the point of interest have been identified in this review. The first rotates the eyes about the neck pivot point (i.e. rotating the head) first to look directly at the object then adjusts the eyes and the second method rotates the eyes first to their maximum angle of rotation and then adjusts the angle about the neck pivot point.

SAE J1050 defines both the maximum and comfortable rotational ranges of motion for the eyes and head based upon recognised anthropomorphic evidence. The eyes may rotate about the vertical and horizontal axes a maximum angle of 30° left, 30° right, 45° up and 65° down and may comfortably rotate 15° left, 15° right, 15° up and 15° down. Furthermore, the head may also rotate about a vertical axis through the neck pivot point to a maximum angle of 60° left and 60° right and may comfortably rotate 45° left and 45° right. As these are recognised standards, based upon a robust evidence base and with no other maximum rotation angles defined by any other procedure, the maximum eye and neck rotational ranges of motion may be the best option for defining the maximum viewpoint ranges of motion in this protocol.



5.2.5.2 Comparison of the methods

Initially, a two-dimensional comparison of the effect of the type of eye-point was completed based on a horizontal cross section at eye height of a commercially sourced HGV model. The comparison considered the following eye-point definitions:

- Monocular fixed – single cyclopean eye-point (midway between the left and right eye) with the head fixed at straight ahead position. This method was considered to be the most basic and least realistic.
- Monocular perpendicular – single cyclopean eye-point that is permitted to rotate about the neck pivot point. While remaining simple, this method is more representative of how the eyes move while driving (although no limit was placed on head rotation at this time)
- Binocular fixed - A pair of eyes with the head fixed at straight ahead position. This method allowed the view from each eye to be considered, although was not realistic with respect to the head rotation.
- Binocular perpendicular - A pair of eyes that are permitted to rotate about the neck pivot point. This method is considered the most representative of the four scenarios considered (although head rotation wasn't limited for this analysis).

Figure 5.5 shows the eye-points and neck rotation points used for this analysis and Figure 5.6 presents the output from the analysis.

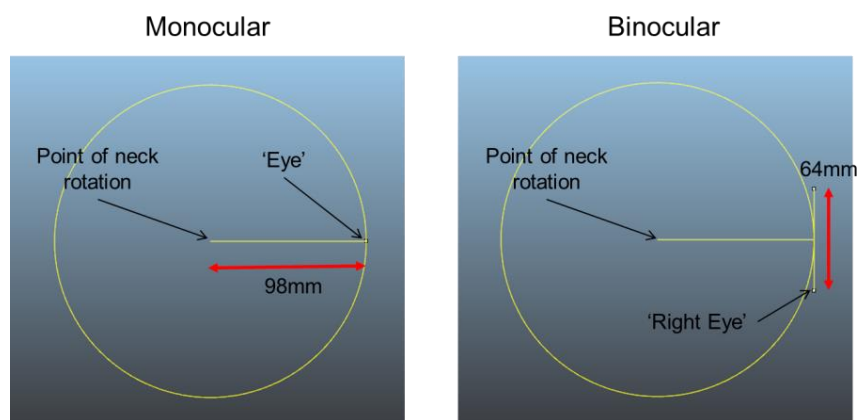
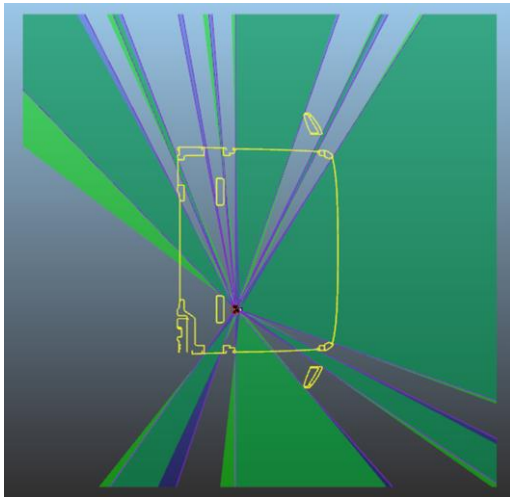
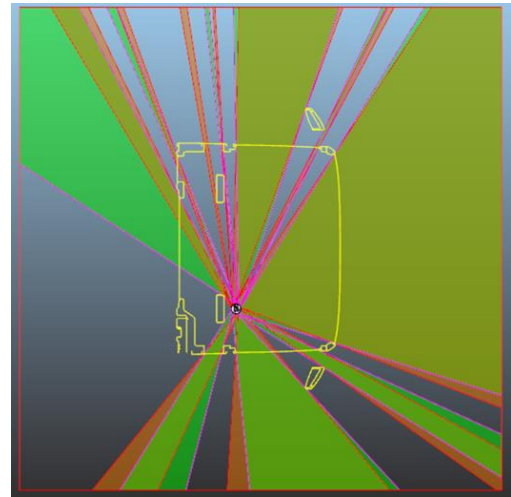


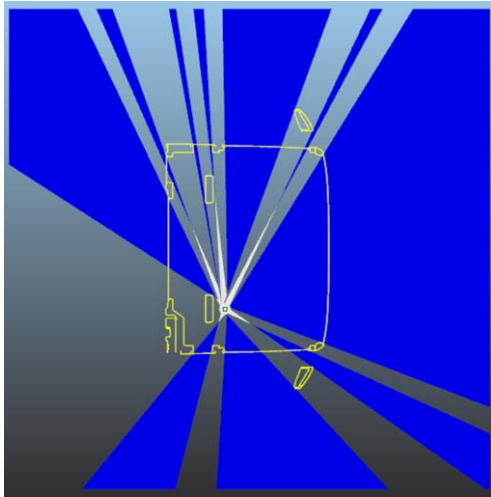
Figure 5.5. Representation of eye-points used for 2D comparison of methods



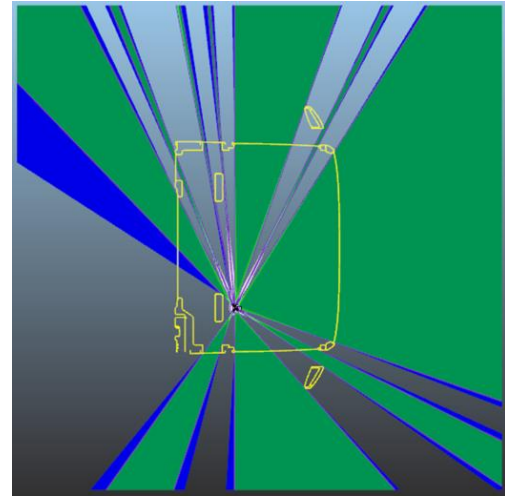
Monocular: fixed (green) vs rotating (blue)



Binocular: rotating – darker shades visible to both eyes



Ambinocular: rotating – blue zones visible to at least one eye



Monocular rotating vs Ambinocular rotating

**Figure 5.6. 2D comparison of eye-point types**

It can be seen that in most areas the differences in projected areas for each method is relatively small until large head angles are reached – i.e. looking through a rear window in the cab. For most HGVs, this area is not relevant because the rear window will only provide a view of the bodywork in the load space. For the forward 180 degree field of view, the variation in projected area between monocular perpendicular and ambinoocular perpendicular was 3.8%.

---

## **5.2.6 Control of vehicle factors affecting eye-position relative to vision obstructions**

### *5.2.6.1 Seat and steering wheel settings*

HGV cabs offer a wide range of adjustment possibilities to accommodate different drivers (e.g. seat adjustment, steering wheel adjustments), different road and driving conditions (e.g. height adjustable air suspension), or different environmental conditions (e.g. sun visors). The adjustment settings will affect the relative position of the driver with respect to the windows and components blocking vision through the windows. This influences the direct field of vision and hence the potential rating a vehicle will achieve for direct vision.

To encourage reproducibility and representativeness, it is necessary to clearly define a reference position for any adjustment in the assessment protocol. The general options for defining a reference position within adjustment ranges are to follow either a best-case, worst-case, or most-representative approach.

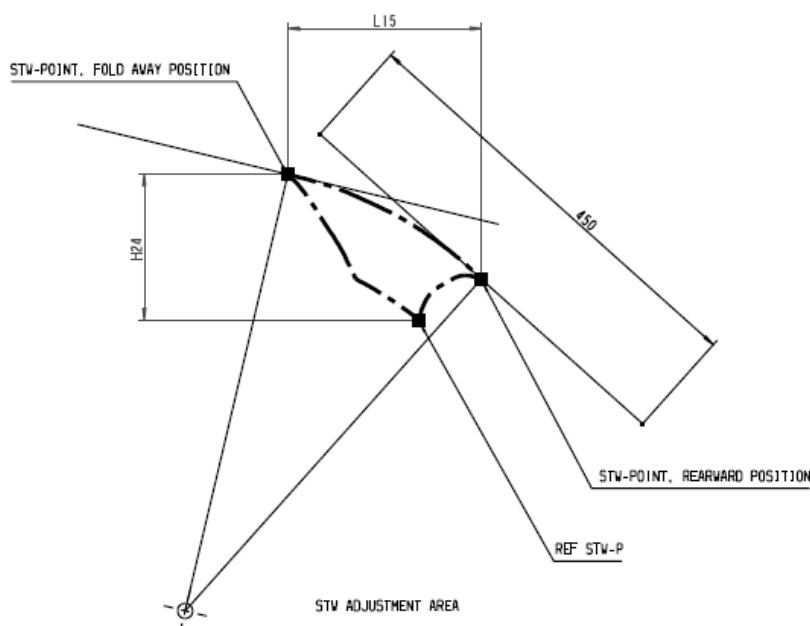
A best-case approach would mean that all adjustments are set to represent the maximum field of view. This approach has two principle disadvantages: Firstly, the results would not be representative of real-world use conditions, because it would be uncommon for a driver to sit with all adjustments set to give maximum visibility, which may conflict with their comfort in the seat and in the driving task. Secondly, any improvements in vehicle design potentially encouraged by the rating would be made at the end of the adjustment range most beneficial for direct vision, which means the most commonly used settings might not be influenced and thus little real-world improvement achieved. Furthermore sometimes the interdependencies between adjustments do not allow a clear best-case position to be defined (e.g. lowering the seat height might reduce vision through the front window but increase vision through a door panel window).

A worst-case approach would perform all adjustments so as to represent the maximum obscuration possible. The advantage of this approach is that the operator can be sure that under no circumstances the vision is worse than reported. The disadvantage is again that the ratings will not represent the most common real-world use conditions (e.g. sun visors are stowed away most of time but would be rated in the use position) and might only encourage design changes that cap the maximum end of an adjustment range but not influence the standard setting used most of the time.

A most-representative approach would try to base the prescriptions on the most likely adjustment of components in real-world use by most drivers. This has the advantage of representing best the conditions used for the majority of time that type of vehicle is driven, encouraging vehicle design improvements to these, commonly used, settings. The disadvantage is that individual vehicles on the road might perform worse than reported when certain settings are applied (e.g. the suspension raised for maximum ground clearance rather than for normal driving).

The steering wheel can present a significant obstruction to the forward field of view of HGV drivers, with this potentially obscuring the view of vulnerable road users walking in front of the HGV during pulling-off manoeuvres (Summerskill, Marshall, Paterson, & Reed, 2015).

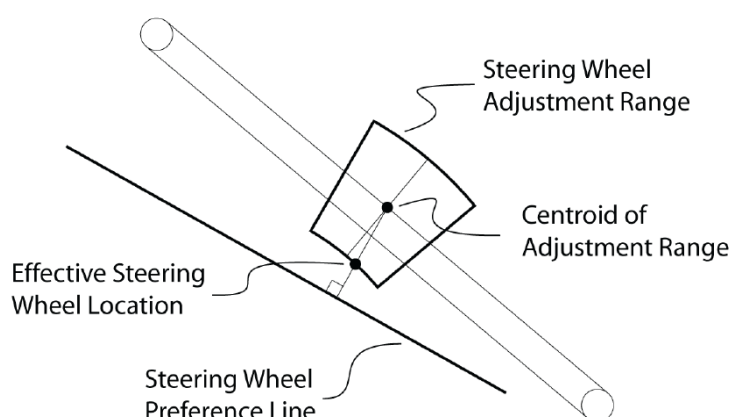
HGV steering wheels can be of varying diameters and can be adjusted through both tilt and telescope functionalities. This can typically result in potentially large and complex steering wheel travel envelopes (Figure 5.7), which can vary significantly between HGV models and are typically much larger and more complex than passenger car steering wheel adjustment ranges. Using the centre of the adjustment range, as is done for passenger car type approval (UN Regulation 125, 2013), or a manufacturer-defined position (such as the steering wheel reference point), may therefore not be appropriate if the adjustment range is not centred on the preferred steering wheel position for the specific HGV driver population.



**Figure 5.7. Steering wheel adjustment travel envelope for example short/medium haul HGV (Vehicle Manufacturer, 2016)**

A steering wheel position model is therefore necessary to define how the steering wheel will be adjusted in the vehicle under test to judge the obscuration of direct vision. Whilst two of the articles reviewed specified steering wheel position, only the UMTRI-2005-30 report defined a HGV-specific steering wheel accommodation model (Reed M. P., 2005).

Reed (2005) provides a comprehensive positioning process that can locate the steering wheel centre-point at a position representing the preferred steering wheel position of a 50<sup>th</sup> percentile HGV driver, relative to the accelerator heel point. This process locates the HGV steering wheel centre-point on a population-specific, 50<sup>th</sup> percentile, steering wheel preference line at the nearest point to the geometric centre of the HGV steering wheel travel envelope. If the closest point to the geometric centre of the travel envelope lies outside of this envelope, however, the point of intersection between the travel envelope and a perpendicular line from the steering wheel preference line to the centroid is then selected as the effective steering wheel location (Figure 5.8).

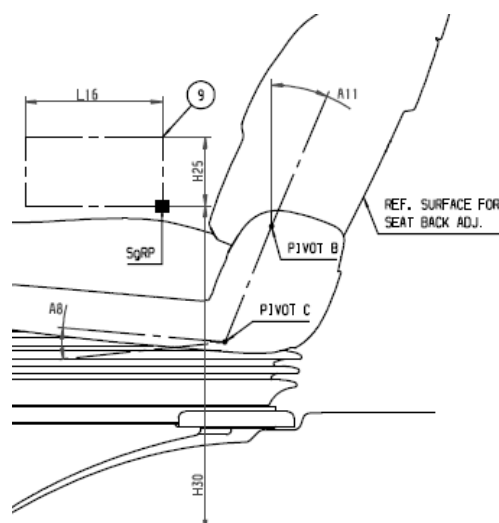


**Figure 5.8. Illustration of effective steering wheel location for a case in which the preference line does not pass through the adjustment range (Reed M. P., 2005)**

With the extraction of UK specific stature data (Measure 2) from the Adultdata database (Peebles & Norris, 1998), in combination with Equation 40 (Reed M. P., 2005), this approach provides a scientifically robust procedure for locating the centre-point of the steering wheel. This will provide a position representing the preferred steering wheel position of a 50<sup>th</sup> percentile HGV driver in the UK. Furthermore, the effective steering wheel location can also be used to locate the eye point centroid at a position representing the eye point of a 50<sup>th</sup> percentile HGV driver (Reed M. P., 2005).

Although it would be expected that the position of the HGV driver seat would determine the location of the eye point, research performed by Reed (2005) found that the position of steering wheel was better correlated with the driver eye point location. The driver seat can still, however, present a significant obstruction to the lateral and rearward fields of view for HGV drivers. This could potentially obscure the view of vulnerable road users positioned alongside HGVs, particularly during low speed turning and manoeuvres. The correct position of the driver seat is therefore fundamental to ensuring a representative assessment of the interior of a HGV cab.

HGV driver seats can be designed to have a range of shapes and sizes and can be fixed, adjustable or air-suspended. Similar to the steering wheel, this typically results in a wide variety of seat position travel envelopes (Figure 5.9) and seat back angles, which vary significantly between HGV models and are typically larger and more complex than car seat ranges. Again, using either the centre of the adjustment range (UN Regulation 125, 2013) or arbitrary positions (e.g. the manufacturer-defined seating reference point or a seat back angle of 25°), may therefore not be appropriate for this standard if they do not relate to the preferred seating position for a specific HGV driver population.



**Figure 5.9. Seat position travel envelope for example short/medium haul HGV (Vehicle Manufacturer, 2016)**

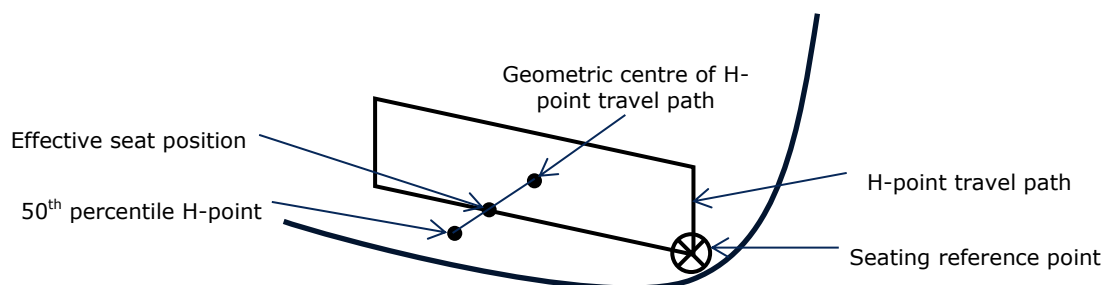
Similar to the steering wheel position model, a seat position model is also necessary to define how the driver seat shall be adjusted in the vehicle under test to judge direct vision obscuration. Whilst 16 articles reviewed specified the driver seat position, only seven articles specified driver seat positions for HGVs. The seat positioning strategies employed by these articles varied widely, with all articles requiring seats to be positioned in the horizontal axis, 11 articles requiring seats to be positioned in the vertical axis, seven articles requiring seat back angles to be defined and only 5 articles requiring any seating suspension to be secured.

When considering vertical and horizontal seat positioning, it is clear that, of the articles specifying a particular seat positioning procedure, the majority of articles preferred to position the seat based on the seating reference point as defined by the manufacturer. The seating reference point (SgRP) is the intended H-point<sup>7</sup> location, as specified by the manufacturer, and is the rearmost normal design H-point for each designated seating position that accounts for all modes of seat adjustment, aside from seat travel (Figure 5.9). The SgRP can, at the discretion of the manufacturer, be located anywhere within the H-point travel path (an area defining all possible H-point locations provided by the full range of seat adjustments for a given designated seating position).

This may potentially lead to large variances in real-world H-point location when the seat is adjusted by the driver and, as the SgRP is used as the fundamental reference point for establishing driver viewpoints, may also consequently affect the viewpoint positions and the direct and indirect fields of view of the HGV driver. This variance in H-point location is further affected by the differences in occupant size, both in height and body mass index (BMI), which have both been proven to affect real-world H-point locations (Guan, Hsiao, Bradtmiller, Zwiener, Amendola, & Weaver, 2015; Reed, Ebert-Hamilton, & Rupp, 2012).

<sup>7</sup> Point at the pivot centre of the back pan and cushion pan assemblies, located on the lateral centreline of a H-point device, that simulates, but does not precisely represent, the location of the human hip joint.

Reed (2005) provides a comprehensive seat positioning process that can locate the SgRP at a position representing the preferred seat position of a 50<sup>th</sup> percentile HGV driver. This process locates the SgRP at the population-specific, 50<sup>th</sup> percentile, H-point location. If the 50<sup>th</sup> percentile H-point lies outside of the H-point travel envelope, however, the point of intersection between the travel envelope and a perpendicular line from the H-point to the centroid of the travel envelope is selected as the effective seat position (Figure 5.10).



**Figure 5.10. Illustration of the effective H-point location for a case in which the 50th percentile H-point is not located within the H-point travel path**

With the extraction of UK specific weight and sitting height data (Measures 1 and 6) from Adultdata (Peebles & Norris, 1998), in combination with Equations 13, 14 and 34-37 from Reed (2005), this approach provides a scientifically robust procedure for locating the driver seat position. This will provide a position that represents the preferred seating position of a 50<sup>th</sup> percentile HGV driver in the UK.

### 5.2.7 Visual obstructions

Objects fitted to the vehicle inside or outside the cab can block the line of sight of the driver through the windows and therefore obscure vulnerable road users under certain circumstances. The protocol therefore needs to ensure that all relevant objects are included in the CAD model for evaluation and give instructions on how to position adjustable equipment (such as the steering wheel or sun visors) in order to achieve a representative, repeatable and reproducible evaluation. Existing research shows that even items such as the steering wheel can obstruct considerable areas in vicinity of the vehicle (Summerskill, Marshall, Paterson, & Reed, 2015).

TRL identified the following common equipment on HGVs that has potential to present a notable obstruction to direct vision:

- Vehicle mirrors (mirror housings can present considerable blind areas)
- Steering wheel
- Passenger, passenger seat and head restraint (presents a potential obstruction in low-mounted side windows or rear windows in flat bed lorries)
- Other equipment that is designed for rare intermittent use, such as windscreen wipers, sun visors or sleeper cab blinds
- Other equipment that is designed to be used while driving, such as adjustable armrests or head restraints

- 
- Windscreen coatings, such as a top edge sun strip or the windscreen frit (a black enamel band that is baked into the edges of the windscreen glass, accompanied by a border of black dots and sometimes covered by a rubber sealing).

Considering more vehicle elements would increase the effort required to complete the assessment, but it also makes the rating more representative of real-world performance.



## 6 Implementation of the Direct Vision Standard

Consideration is required as to how the Direct Vision Protocol will be implemented within a policy framework and in industry. A couple of exemplary aspects that require attention for the implementation of the protocol are described below.

### 6.1 Who will carry out the assessment?

The Direct Vision Standard could be implemented through a self-certification approach by the vehicle manufacturers or through independent testing. While most vehicle manufacturers preferred the self-certification approach, more than one thought an independent approach would be better, at least initially until the process became established. For both approaches, deviations can occur between the reported rating and the actual performance of production vehicles, possibly because of deviations in production parts from the 3D CAD model used, undocumented changes in specifications, application of results to vehicle variants that are not covered by an assessment, etc. This makes it necessary to define a procedure for verifying the performance of a sample vehicle.

Two procedures have been defined with different stringency. The more stringent procedure fulfils a similar function to legislative market surveillance measures:

- **A vehicle spot check procedure:** A brief physical inspection to determine whether important direct vision characteristics of an individual vehicle are in accordance with those of the rating certificate presented. This check is intended to be carried out, for example, at construction sites to test samples of contractors' fleets. Key dimensions such as overall vehicle height, height to lower edge of the windscreen etc are measured manually and compared to those in the Test Report which is generated in support of that vehicle's certification. This shall give assurance that a presented rating certificate is applicable to the vehicle being used and that it is kept and maintained in a compliant condition. Any substantial deviation can be flagged for a full compliance check if it causes concerns.
- **A compliance test procedure:** A comprehensive verification of the performance of an actual production vehicle as representation of that vehicle model. Carried out, for example, by an independent test house after failed vehicle spot checks or at random. This shall give independent assurance that a production vehicle model indeed achieves the reported rating of that model.

### 6.2 How does the assessment apply to a range of vehicle specifications?

For practical reasons, not every individual vehicle driving on the road and also not every possible combination of chassis, cab and cab equipment can be scanned (in 3D), evaluated and assessed.

A best-case approach for applicability of ratings would be to test only the variant of a vehicle or cab model that offers the best field of view and then to allow the manufacturer to advertise the achieved rating for all other variants. This would show what is possible for the vehicle range, but may not be true for all variants. A worst-case approach would test only

the worst variant, thereby ensuring that the direct vision will be no worse throughout the range than for the variant assessed. An alternative would be the selection of the best-selling variant, which would require sales information from the manufacturer.

It remains possible that a rating of one variant is equally applicable to another variant. However, to define which variants can share the rating would require the definition of a set of technical criteria to which the variants do not deviate, making the direct vision rating applicable to all such variants. This approach is commonly taken in vehicle type-approval legislation to define what constitutes the same vehicle 'type'.

Vehicle design factors that affect direct vision performance of a vehicle are:

- Number and size of windows, because these directly influence the view of the road afforded by the cab.
- Height above ground and width of the cab, because these were found in research to have a strong influence on blind spots around the vehicle (Summerskill et al., 2015).
- Engine tunnel height, because this may obscure the view through low-mounted side windows (door panel windows) to a greater or lesser extent.
- Additional cab equipment because this might present visual obscuration for parts of the windows.

The choice of variants to test will largely be a policy decision for TfL and the industry. However, the Direct Vision Standard includes a technical definition of the properties that must not vary if the rating is to be considered applicable to more than the tested variant.

### 6.3 Control of unintended consequences

As already identified, some VRU crashes do occur at the offside when pulling away and turning right. These might increase in frequency if some vehicle designs worsen that view, so consideration of a zone on the offside, as a mirror image of the nearside zone, may be useful. Similarly, a wide variety of traffic conflicts occur with other vehicles and VRUs positioned at a distance from the vehicle and there is a need to see traffic signs and signals. These requirements exist at similar heights to vulnerable road users but outside of the close proximity zones defined and also at higher vertical levels for tall vehicles, traffic lights and overhead gantry signs etc. Analyses have been undertaken to assess the position of relevant objects and parallels can be drawn with the minimum standards implemented for passenger cars in UN Regulation 125. However, the zones of vision for these areas are large in relation to the close proximity zones and if included directly in a rating can make the procedure insensitive to changes in the close proximity zones. Thus, the approach needs to be balanced between the areas a driver needs to see to avoid collisions, the more distant vision performance of typical existing vehicles, and the objectives to discriminate between vehicles that differ mainly in close proximity areas.

## 7 Stakeholder engagement

Throughout the project, stakeholder engagement was maintained, focussing on freight operators and vehicle manufacturers. The aim was to maximise the chances of acceptance of the protocol by identifying and, as far as possible, incorporating in the draft proposals measures to help achieve their aims, and minimise their concerns and constraints. This task involved attendance at existing forums, such as CLOCS, telephone interviews and face to face meetings. TRL and TfL would like to thank all those stakeholders who participated in the interviews and meetings.

The feedback obtained is summarised in Appendix D, with the key themes highlighted below:

### 1. Considerations for implementing a Direct Vision Standard

Timescales for introduction of a standard are key to understanding the cost implications and ease of implementation

There is a need to adopt an holistic approach, including driver training and road user awareness.

Cost implications are linked to timescales. Consideration of how costs will be distributed among the stakeholders is required.

Ability to use vehicles in different environments – flexible fleet.

### 2. Risk

Too many standards to meet leading to confusion and increased costs.

Sensory overload for the drivers needs to be considered with respect to the driving task, particular mention of indirect visibility aids was made. Solutions that provide the best vision possible with minimal distraction are needed.

Assess the risk and prioritise vehicles that pose highest risk. Does the standard need to apply to all industries if there are currently no issues in those industries.

Risk that solutions proposed won't solve the issues as direct vision alone will not resolve all blind spots or overcome poor awareness of interactions between different road users.

### 3. Solutions

Concern relating to the Standard being London specific affecting running costs for contracts delivered outside London using the higher specified vehicles that are required for London.

Standard needs to be clear and specific, creating a level playing field.

There is currently no off the shelf solution for improving vehicle design.

Any standard that is implemented should be aligned with the current and proposed standards for Europe.

An integrated approach considering driver training and improved road user awareness leading to a shared burden of cost.

---

Incentivise change to ensure timely uptake of improved vehicle designs

Direct vision is not currently a priority within the procurement process. Implementation of a standard would raise the profile of the issue.

---

## 8 Conclusions & future considerations

The following conclusions can be drawn from this research:

A wide variety of standards exist for measuring the field of view from vehicles. However, no individual existing standard or method for measuring direct vision entirely met the objectives of this research programme.

A draft TfL Direct Vision Assessment Protocol has been designed that measures and categorises the direct field of view using a five star rating scheme. The scoring system is designed as a flexible system that allows the vehicle industry scope to innovate, in the way they see best, in order to achieve the highest possible performance for their vehicle while continuing to meet the needs of the market. It does not prescribe a particular design solution to improve direct vision. The five star rating rewards small improvements to the direct vision performance and avoids the use of descriptive category titles that could be open to interpretation.

The Direct Vision Assessment Protocol was applied to eight vehicles (four standard vehicles, one with two different modifications).

- An example of standard off-road vehicle (N<sub>3</sub>G) achieved zero stars.
- The same off-road (N<sub>3</sub>G) vehicle could achieve one star if modified to add a window in the lower panel of the passenger door or by re-modelling the dashboard such that it did not intrude on the forward vision at the lower edge of the windscreen.
- Two N<sub>3</sub> on-road specification vehicles (one rigid, one articulated) achieved two and three stars respectively. It is likely the N<sub>3</sub> rigid vehicle could achieve three stars by combining both the additional side window and re-modelled dashboard.
- The only vehicle assessed capable of achieving five stars was a specialist, low entry design.

While the results for these vehicles are as may have been expected, the sample of vehicles to which the assessment protocol has been applied is limited with respect to the range of vehicle models within the vehicle fleet.

Implementation of a five star performance requirement would be expected to make visible an easily recognisable proportion of most of the pedestrians killed in relevant HGV collisions, at a time when the driver should be able to avoid the collision. This is also true for a number of the cyclists killed in relevant collisions. However, in the case of cyclists there is also a significant proportion that will not be within the scope of improved direct vision because they are positioned too far to the rear of the cab at the critical moment when the driver would need to act to allow the collision to be avoided.

The assessment is currently based on the weighted proportions of the visibility zones that can be seen by a driver. There is currently no requirement that the driver must be able to see a defined proportion of each zone. A minimum proportion for each zone could be implemented to allow progression between bands, but this will require analysis of a larger number of vehicle models.

---

The proposed protocol allows the categorisation of HGVs in relation to their ability to allow vision of vulnerable road users in close proximity at a time that would allow fatal collisions to be avoided. It has been written for potential use in procurement procedures for TfL. The standard is based on an internationally recognised format to allow it to be considered for a wider application. Extending the scope of application of the TfL Draft Visibility Protocol, for example to apply across Europe, may require changes to the size of people considered and different collision data may be needed to ensure the geometry of zones and their weighting fully represented the wider population.

When used, the effect of implementing the assessment protocol should be monitored in terms of the prevalence of new cab designs, such as low entry cabs with increased numbers of pillars, and their relative involvement in collisions. If necessary, the assessment methods can be refined to maximise the benefits achieved and minimise any design changes which may have a negative effect on safety.

## 9 References

- ACEA, JAMA, KAMA. (2004). *Preparation of Euro NCAP visibility protocol: Practical aspects of measurement methods for direct and indirect visibility assessments*. ACEA, JAMA, KAMA.
- Bast & GDV. (2003). *Code of Practice for evaluation of road traffic accidents*. Road and Transportation Research Association, Working group traffic engineering and safety.
- Caterpillar Inc. (2004). *Construction Vehicle and Equipment Blind Area Diagrams: Contract Modification - Final Report*. Caterpillar Inc., Peoria, Illinois.
- Cookson, R., & Knight, I. (2010). *Sideguards on Heavy Goods Vehicles: Assessing the effects on pedal cyclists injured by trucks overtaking or turning left*. Crowthorne: PPR514, TRL Limited.
- Dekra. (2014). *Kollisionen zwischen rechts abbiegenden LKW und Fahrradern - ein update nach zehn jahren*. Verkehrsunfall und Fahrzeugtechnik.
- Delmonte, E., Manning, J., Helman, S., Basacik, D., Scoons, J., Chappell, J., et al. (2012). *Construction logistics and cycle safety: Technical Report*. Crowthorne: TRL Limited, PPR 639.
- Delmonte, E., Manning, J., Helman, S., Basacik, D., Scoons, J., Chappell, J., et al. (2013). *Construction logistics and cyclist safety: Technical report*. Transport Research Laboratory (TRL), Crowthorne.
- FMVSS 104. (2014). *Windshield wiping and washing systems*. Federal Motor Vehicle Safety Standards (FMVSS).
- Gates, T., Noyce, D., Bill, A., & Van Ee, N. (2006). *Recommended walking speeds for pedestrian clearance timing based on pedestrian characteristics*. Washington: Transportation Research Board Annual Meeting.
- GRSG expert from Japan. (2003). *National Regulations concerning Driver's field of vision of immediate frontward and sideward*.
- GRSG expert from Japan. (2015). *Study of Pedestrian's fatal accidents (vs. motor vehicles at low speed) in Japan*. MLIT, Geneva.
- Guan, J., Hsiao, H., Bradtmiller, B., Zwiener, J. V., Amendola, A. A., & Weaver, D. L. (2015). *Anthropometric Study of U.S. Truck Drivers: Methods, Summary Statistics, and Multivariate Accommodation Models*. Morgantown, WV, USA: National Institute for Occupational Safety and Health (NIOSH).
- ISO 4513. (2010). *Road vehicles - visibility - method for establishment of eyellipses for driver's eye location*. BS ISO 4513:2010.
- ISO 5006. (2006). *Earth-moving machinery - Operator's field of view - Test method and performance criteria*. BS ISO 5006:2006.
- Jia, Y. (2015). *Developing a collision avoidance system for left-turning trucks*. Cambridge: Submitted as PhD thesis to Cambridge University Engineering Department.

- 
- Jia, Y., & Cebon, D. (2015). *A strategy for avoiding collisions between heavy goods vehicles and cyclists*. JMES 15-0725.
- Knight, I. (2011). *A study of the implementation of Directive 2007/38/EC on the retrofitting of blind spot mirrors to HGVs*. Crowthorne: TRL Limited.
- Knight, I., & Simmons, I. (2000). *Countermeasures for safer commercial vehicles*. Saskatoon: Proceedings of the 6th International Symposium on Heavy vehicles Weights and Dimensions.
- Knight, I., Grover, C., Brook-Carter, N., Dodd, M., Clift, L., & Cherry, A. (2005). *The Development of Test Methods for a Primary Safety New Car Assessment Programme: Final Report*. Crowthorne: TRL Limited.
- Knowles, J., Smith, L., Cuerden, R., & Delmonte, E. (2012). *Analysis of police collision files for pedestrian fatalities in London 2006-2010*. Crowthorne: PPR 620 TRL Limited.
- Mazzae, E. N., & Garrott, W. R. (2008). *Light Vehicle Rear Visibility Assessment*. Washington, DC, US: National Highway Traffic Safety Administration.
- MLIT. (2015). *Study of Pedestrian fatal accidents vs motor vehicles at low speeds in Japan*. Geneva: UNECE Informal document GRSG-109-20 109th GSRG meeting.
- OVSC. (1999). *Laboratory test procedure for FMVSS - School bus rearview mirrors*. Office of Vehicle Safety Compliance (OVSC).
- OVSC. (1999). *Laboratory test procedure for FMVSS 111 - Rearview mirrors (other than school buses)*. Office of Vehicle Safety Compliance (OVSC).
- Peebles, L., & Norris, B. (1998). *Adultdata: the handbook of adult anthropometric and strength measurements: data for design safety*. London: Department for Trade and Industry.
- Reed, M. P. (2005). *Development of a new eyellipse and seating accommodation model for trucks and buses*. University of Michigan Transportation Research Institute, Michigan.
- Reed, M. P., Ebert-Hamilton, S. M., & Rupp, J. D. (2012). Effects of Obesity on Seat Belt Fit. *Traffic Injury Prevention*, 13(4), 364-372.
- SAE J1050. (2009). *Describing and measuring the driver's field of view*. Society of Automotive Engineers (SAE).
- SAE J1750. (2010). *Describing and evaluating the truck driver's viewing environment*. Society of Automotive Engineers (SAE).
- Schreck, B., & Seiniger, P. (2014). *Turn Assist Systems for Goods Vehicles*. Bergisch Gladbach: German Federal Highway Research Institute (BaST).
- Smith, T., Schmitt, B., Neiwöhner, W., Aparicio, A., Fassbender, S., Hamacher, M., et al. (2008). *APROSYS SP 2: Guidelines of assessment criteria for HV passive safety test methods*. Transport Research Laboratory (TRL), Crowthorne.
- Summerskill, S., & Marshall, R. (2014). *The Design of category N3 vehicles for improved driver direct vision*. Brussels: Transport & Environment/Transport for London.
-



- 
- Summerskill, S., Marshall, R., Paterson, A., & Reed, S. (2015). *Understanding direct and indirect driver vision in heavy goods vehicles: Final report*. Loughborough Design School, Loughborough University, Loughborough.
- Talbot, R., Reed, S., Barnes, J., Thomas, P., & Christie, N. (2014). *Pedal Cyclist Fatalities in London: Analysis of Police Collision Files (2007-2011)*. Loughborough: Loughborough University.
- Teizer, J., Allread, B. S., & Mantripragada, U. (2010). Automating the blind spot measurement of construction equipment. *Automation in Construction*(19), 491-501.
- Torkington, C., Robbins, R., Jenkins, D., & McCarthy, M. (2015). *HGV VRU test protocol: Final project report*. Transport Research Laboratory (TRL), Crowthorne.
- TRL. (2003). *PNCAP Visibility Protocol - version 1.12*. Wokingham: TRL Limited.
- TRL. (2003). *PNCAP: Direct visibility test result - Mercedes Model (Unpublished)*. Crowthorne: Transport Research Laboratory.
- UN Regulation 125. (2013). *Uniform provisions concerning the approval of motor vehicles with regard to the forward field of vision of the motor vehicle driver*. United Nations Economic Commission for Europe (UNECE).
- UN Regulation 46. (2014). *Uniform provisions concerning the approval of devices for indirect vision and of motor vehicles with regard to the installation of these devices*. United Nations Economic Commission for Europe (UNECE).
- Vehicle Manufacturer. (2016). *Seat and Steering Wheel Positioning Diagrams. (Personal Correspondance)*.

## Appendix A Review and identification of “area of greatest risk”

None of the existing methods of rating and scoring was tailored specifically to the objectives of a test protocol aimed at improving the direct vision from new vehicles in London, in order to better protect vulnerable road users without compromising other aspects of the view. An analysis of the crash mechanism was, therefore, undertaken from first principles in order to establish an independent set of requirements.

Pedestrians and pedal cyclists were considered to be the main types of vulnerable road user (VRU) for this analysis, although motorcyclists are often considered within the VRU category. Alongside the pedestrians and cyclists, brief consideration of other crash types and normal driving tasks has been included within the project. The following section describes the importance of each of the main casualty groups; their key characteristics and how a desired view zone has been derived.

### A.1 Pedestrians

#### A.1.1 Importance of pedestrian collisions

##### A.1.1.1 National data

The UK National accident database (Stats 19) shows that in 2014 almost 195,000 casualties were reported to police as a result of road accidents. One thousand, seven hundred and seventy-five of these were killed (0.9%) and a further 22,807 were seriously injured (11.7%).

Within this national sample, pedestrians represented almost 13% of all casualties but 22% of serious injuries and 25% of all fatalities. The detailed numbers are explored in Table A.1, below.

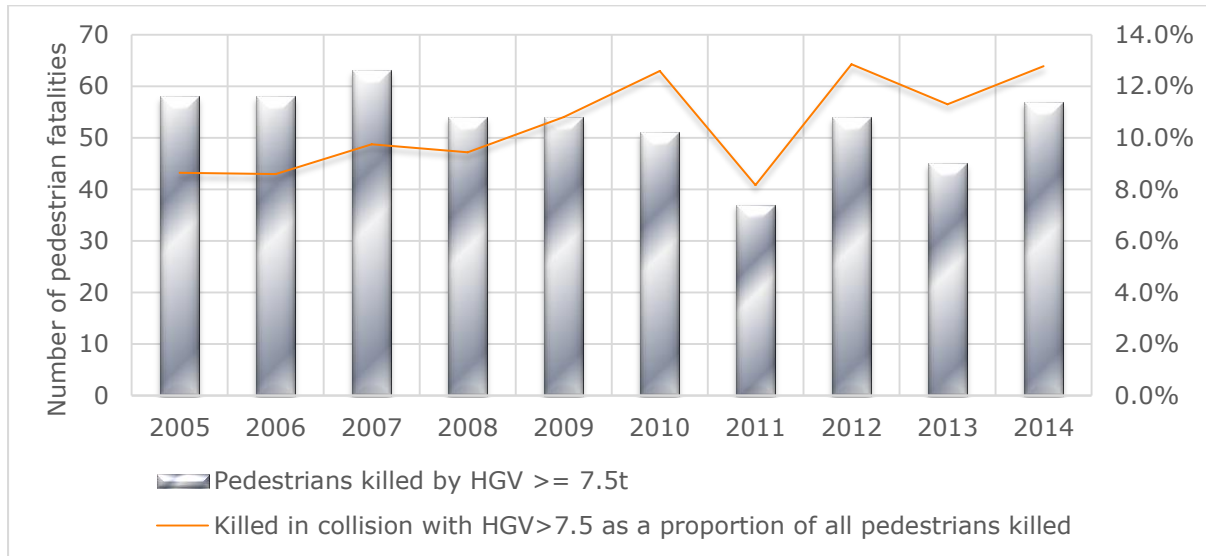
**Table A.1. GB pedestrian casualties from accidents in 2014, by vehicle type struck.**  
Source: Stats 19.

	Struck by vehicle type...		
	All vehicles	HGV > 3.5t < 7.5t	HGV ≥ 7.5t
<b>Fatal</b>	446 (100%)	16 (3.6%)	57 (12.8%)
<b>Serious</b>	5,063 (100%)	41 (0.8%)	64 (1.3%)
<b>Slight</b>	19,239 (100%)	130 (0.7%)	127 (0.7%)
<b>Total</b>	24,745 (100%)	187 (0.8%)	248 (1.0%)

When considering the severity distribution of pedestrians in collisions with an HGV ≥ 7.5t, it can be seen that 57 (23%) of the 248 casualties were killed, which compares with just 1.8% (446 of 24,748) for all pedestrian casualties and 0.9% (1,775 of almost 195,000) when all casualty types are included.

Nationally, HGVs of all weights in excess of 3.5 tonnes constituted about 5% of all traffic (vehicle kms) on UK roads<sup>8</sup>. It can be seen that overall they are substantially under-involved in pedestrian collisions when all severities are considered, most likely because most of their travel distance is completed on roads such as motorways and dual carriageways which are less frequently used by pedestrians. However, the larger vehicles (>7.5tonnes) are substantially over involved in pedestrian fatalities, where their size and weight are such that when they do become involved, the collision tends to be serious.

The data related to fatalities from collisions involving HGVs>7.5t has been studied in more depth and Figure A.1, below shows an analysis over time.



**Figure A.1. Trend in GB pedestrian fatalities from collisions involving an HGV ≥ 7.5 tonnes.**  
**Source: Stats 19.**

The data presented contains considerable variation from year to year, making it hard to identify trends. However, there is a reasonably consistent suggestion that the number of pedestrians killed in collision with an HGV >7.5t represented a growing proportion of all pedestrians killed (i.e. other pedestrian crashes were reducing).

The data from fatal cases where an HGV ≥ 7.5t struck a pedestrian have been divided by the location of the impact on the vehicle and the manoeuvre the vehicle was making immediately prior to the collision (Table A.2).

<sup>8</sup> [https://www.gov.uk/government/uploads/system/uploads/attachment\\_data/file/428671/annual-road-traffic-estimates-2014.pdf](https://www.gov.uk/government/uploads/system/uploads/attachment_data/file/428671/annual-road-traffic-estimates-2014.pdf)

**Table A.2. GB pedestrians killed by HGVs ≥7.5 tonnes divided by 1<sup>st</sup> point of impact and pre-impact manoeuvre. Source: Stats 19 years 2005-14 inclusive.**

Vehicle_Manoevre	1st point of impact					Total
	Unknown	Front	Back	Offside	Nearside	
Reversing	0	1	21	0	4	26
Parked	2	0	1	1	2	6
Waiting to go - held up	1	0	0	0	1	2
Slowing or stopping	0	4	0	3	0	7
Moving off	6	77	2	2	9	96
U-turn	0	0	0	0	1	1
Turning left	3	11	0	1	17	32
Waiting to turn left	0	0	0	0	0	0
Turning right	0	8	0	2	3	13
Waiting to turn right	0	0	0	0	0	0
Changing lane to left	0	1	0	0	0	1
Changing lane to right	0	2	0	0	0	2
Overtaking moving vehicle - offside	0	0	0	0	0	0
Overtaking static vehicle - offside	0	4	0	0	0	4
Overtaking - nearside	0	0	0	0	0	0
Going ahead left-hand bend	0	4	0	1	3	8
Going ahead right-hand bend	1	6	0	0	3	10
Going ahead other	14	244	3	9	53	323
Total	27	362	27	19	96	531

It can be seen that almost half (46%) of all fatalities were killed in a collision with the front of an HGV that was “going ahead other”. This is typically coded for a collision where the pedestrian crosses a straight road in front of an HGV travelling at normal traffic speeds and sometimes where a pedestrian walking along the road is struck by the front of an HGV approaching from behind. It is, therefore, relatively unlikely to be a collision mechanism much affected directly by vehicle blind spots. The next largest group of fatalities (15%) occurs at the front of the vehicle when the vehicle was categorised as “moving off” immediately prior to the collision. Other research, e.g. (Knight & Simmons, 2000) that has reviewed police fatal accident reports in detail has shown that this type of accident usually involves an HGV moving away from rest at a junction or in a traffic jam at the same time as a pedestrian is crossing in front of the vehicle. In almost all of these cases it was concluded that the pedestrian was in the driver’s frontal blind spot at the time of the collision.

The 3<sup>rd</sup> largest group (10%) is where the HGV is ‘going ahead other’ and a pedestrian collides with its nearside. Typical collision circumstances for this group are not clear but may include pedestrians stepping or falling into the side of a moving HGV as it passes.

The 4<sup>th</sup> largest group (6%) is pedestrians killed when an HGV is turning left. This can involve pedestrians crossing or waiting to cross a side road as an HGV turns left into it. The swing out at the front and cut-in at the rear can potentially cause pedestrians to

mis-interpret the path of the vehicle. Collisions are typically at the nearside (3%) or front (2%) of the HGV. This may potentially be affected by vehicle blind spots.

Turning right accounted for just over 2% of pedestrian fatalities from collisions involving heavy trucks, split approximately two-thirds to the front and one third to the side.

Evidence from Japan (MLIT, 2015) supports the view that starting from rest is a significant accident mechanism for trucks exceeding 7.5 tonnes in mass, noting that around 16 % of fatalities involved a low speed collision when starting. However, this was not cross-tabulated with impact point so compares to the total for the 'moving off' manoeuvre in the stats 19 data (20%) so slightly less important than in GB. Similarly, turning left (all impact locations) at low speed was found to represent 9.5% of pedestrian fatalities, almost double the proportion found in GB, suggesting this mechanism is substantially more important in Japan than in GB.

#### A.1.1.2 London data

The national Stats 19 database can identify accidents reported by the Metropolitan or City of London Police, which is a close approximation for London. Based on this definition, there were 4,836 pedestrian casualties in London in 2014 of which 66 were killed and 715 seriously injured. This represents almost 15% of the UK national pedestrian deaths, a very substantial proportion.

The vehicle that collided with the pedestrian in each of these cases is identified in Table A.3, below.

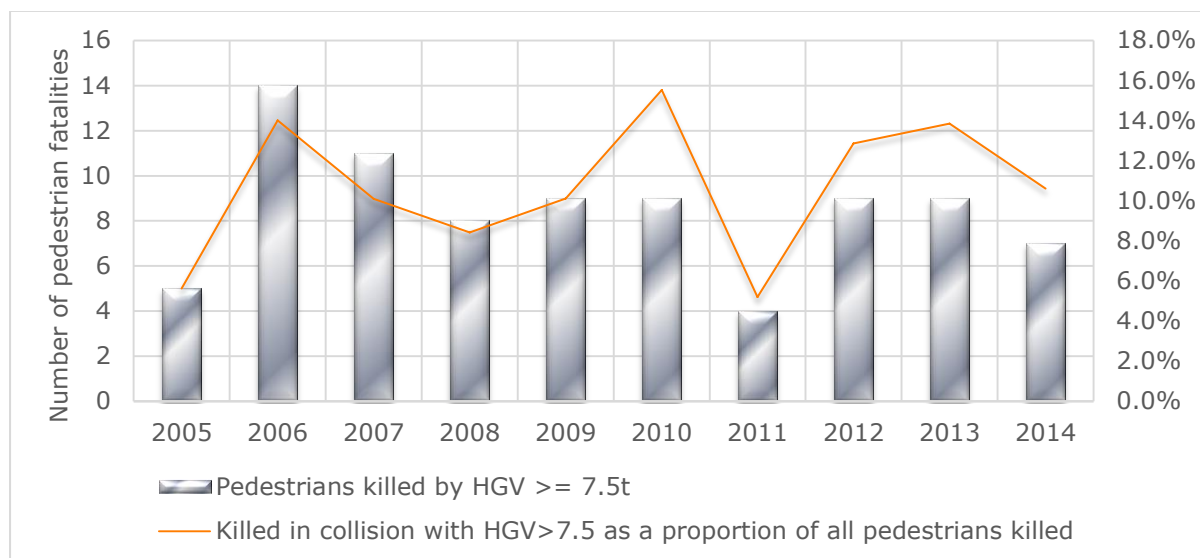
**Table A.3. London pedestrian casualties from accidents in 2005-2014 inclusive, by vehicle type struck. Source: Stats 19.**

	Struck by vehicle type...		
	All vehicles	HGV > 3.5t < 7.5t	HGV ≥ 7.5t
<b>Fatal</b>	818 (100%)	20 (2.4%)	85 (10.4%)
<b>Serious</b>	9,906 (100%)	81 (0.8%)	162 (1.6%)
<b>Slight</b>	43,384 (100%)	257 (0.6%)	280 (0.6%)
<b>Total</b>	54,108 (100%)	358 (0.7%)	527 (1.0%)

The pattern is similar to national data. In London, trucks represent just 4% of traffic<sup>9</sup>. In total, only 1.6% of pedestrian casualties arise from collisions involving trucks over 3.5 tonnes, a significant under-involvement which suggests overall they are less likely per mile to get involved in a collision with a pedestrian. However, this rises to 10.4% if only fatalities and larger trucks are considered. This is a substantial over-involvement, though marginally less so than for GB as a whole.

<sup>9</sup> Source: TfL

Fatalities from collisions involving HGVs >7.5t have been studied in more detail in Figure A.2, below.



**Figure A.2. Trend in London pedestrian fatalities from collisions involving an HGV ≥ 7.5 tonnes. Source: Stats 19.**

It can be seen that there is no overall discernible trend and the variation is essentially random and of greater magnitude than for GB as a whole, which is typical of accident groups with relatively low numbers. This suggests little underlying change over the years.

The impact point and manoeuvre involved in fatal pedestrian collisions in London involving an HGV ≥ 7.5 tonnes are shown in Table A.4.

Comparing the results in Table A.4 for London with those in Table A.2 for GB as a whole suggests a considerably different distribution. In London, pedestrians killed in collision with the front of an HGV as it moves off from rest are the joint largest crash group (25% of all pedestrian fatalities from collisions with a large truck, compared with 6% for GB as a whole). This strongly suggests that this crash type is a particular problem in London. Fatalities in collision with the front of a vehicle 'going ahead other' are equally frequent.

Collisions involving the truck turning left are also significant though the impact point is varied with 6% at the nearside, 4% unknown and 2% at the front. Turning right represents just 2% of all fatalities, split equally between collisions at the front and offside.

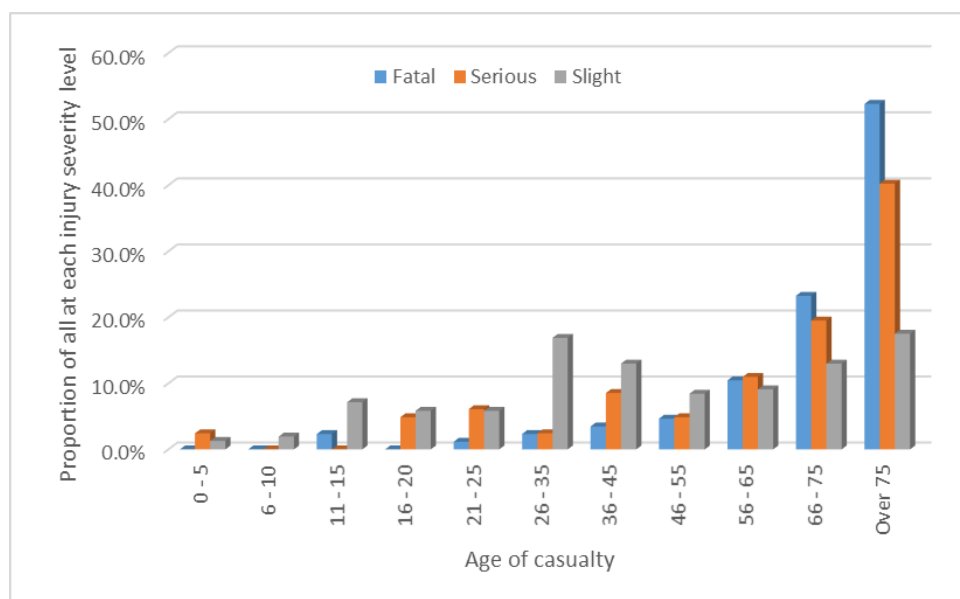
**Table A.4. London pedestrians killed by HGVs ≥7.5 tonnes divided by 1<sup>st</sup> point of impact and pre-impact manoeuvre for the HGV. Source: Stats 19 years 2005-14 inclusive.**

Vehicle Manoeuvre	1st point of impact					Total
	Unknown	Front	Back	Offside	Nearside	
Reversing	0	0	0	0	1	1
Parked	1	0	0	0	0	1
Waiting to go - held up	0	0	0	0	0	0
Slowing or stopping	0	3	0	1	0	4
Moving off	4	21	1	1	4	31
U-turn	0	0	0	0	0	0
Turning left	3	2	0	1	5	11
Waiting to turn left	0	0	0	0	0	0
Turning right	0	1	0	1	0	2
Waiting to turn right	0	0	0	0	0	0
Changing lane to left	0	0	0	0	0	0
Changing lane to right	0	0	0	0	0	0
Overtaking moving vehicle - offside	0	0	0	0	0	0
Overtaking static vehicle - offside	0	1	0	0	0	1
Overtaking - nearside	0	0	0	0	0	0
Going ahead left-hand bend	0	0	0	0	0	0
Going ahead right-hand bend	0	0	0	0	0	0
Going ahead other	3	21	0	2	8	34
<b>Total</b>	<b>11</b>	<b>49</b>	<b>1</b>	<b>6</b>	<b>18</b>	<b>85</b>

**A.1.2 Detailed characteristics of pedestrian crashes influenced by field of view**

Collisions where pedestrians are injured by an HGV moving away from rest have been analysed in more depth. The previous section showed no strong trends over time and there is no other evidence to suggest that this collision mechanism has changed much over time. The subsequent analyses have, therefore, been based on GB data from multiple years (2005-13 inclusive) in order to maximise numerical confidence. The analysis identified 328 casualties from collisions where an HGV ≥7.5tonnes collided with a pedestrian while “moving off”. Eighty-six (26%) of these were killed and a further 85 (26%) were seriously injured. Figure A.3 shows the distribution of these casualties by age.

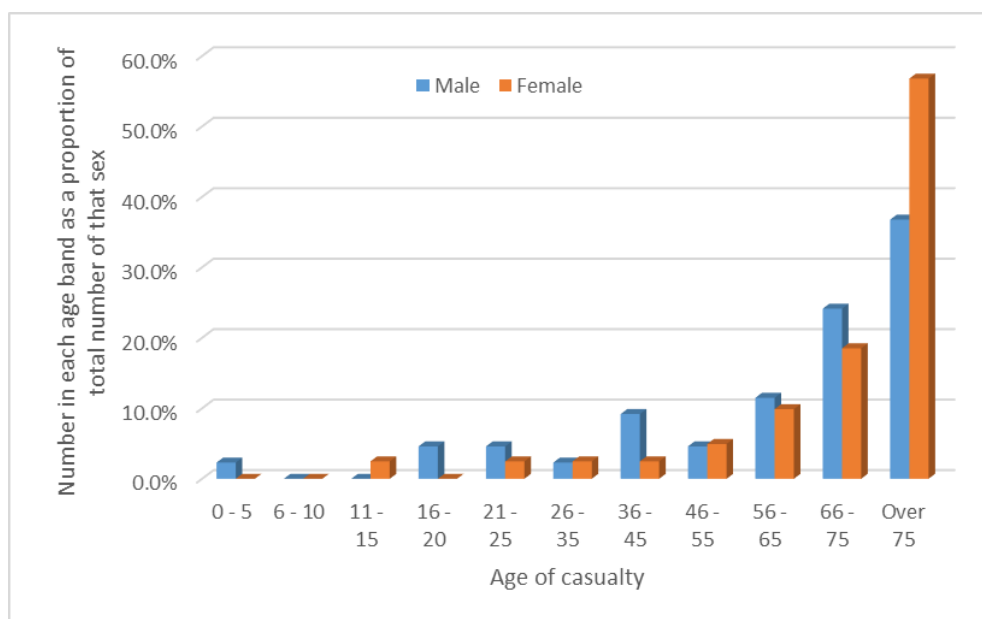




**Figure A.3. Age distribution for pedestrians injured in collision with HGVs≥7.5 tones when “moving off”. Source: Stats 19 GB 2005-13.**

It can be seen that elderly pedestrians are commonly involved in incidents of all severity levels but that the distribution is dramatically skewed for serious and fatal incidents, culminating in more than half of all fatalities being aged more than 75 at the time of the collision. When individual case studies are reviewed, witness statements will often describe the engine revving as the vehicle prepares to pull away. This could potentially give a pedestrian situated in front of the vehicle a short period of advanced warning that the vehicle is about to move and might hit them. One possible theoretical explanation for the high involvement of elderly people in this crash type is that elderly people might be less successful than younger people either in identifying the inadvertent warning of imminent danger or, if the threat is identified, in their ability to speed up their movement and get out of the path of the vehicle before the point of collision.

Overall the distribution by gender for those collisions resulting in death or serious injury was fairly even with 52% male and 48% female. However, there was a greater age dependency for females than males, with 57% of killed or seriously injured females aged more than 75 compared with only 37% of killed or seriously injured males. This is illustrated in Figure A.4, below.



**Figure A.4. Distribution of age and gender of pedestrians killed or seriously injured in collision with an HGV ≥ 7.5t when “moving off”. Source: Stats 19 GB 2005-13.**

Stats 19 does not hold any more detailed data that was relevant to this crash type and the ability to prevent it by improved direct vision. However, (Knowles, Smith, Cuerden, & Delmonte, 2012) studied police fatal collision reports relating to pedestrian crashes in London and extracted more detail which showed that 15 of the 27 fatalities involving an HGV involved moving off from rest. It also showed that 6 of the 27 vehicles were construction vehicles and 2 of the 27 were not equipped with a frontal (Class VI) blind spot mirror. Unfortunately, it did not cross correlate these parameters to quantify the proportion of construction vehicles or the proportion with and without a blind spot mirror specifically for accidents involving “moving off”.

The EU funded APROSYS project undertook an analysis of collisions between HGVs and pedestrians in the ‘moving off’ scenario. The sample of crashes with data available was relatively small but only one child was involved (height 140cm) and all other casualties were taller than 1.5m.

No information has been identified quantifying the movement and lateral position of pedestrians at the critical moment or how far they are in front of the vehicle.

## A.2 Pedal cyclists

### A.2.1 Importance of pedal cycle collisions

#### A.2.1.1 GB

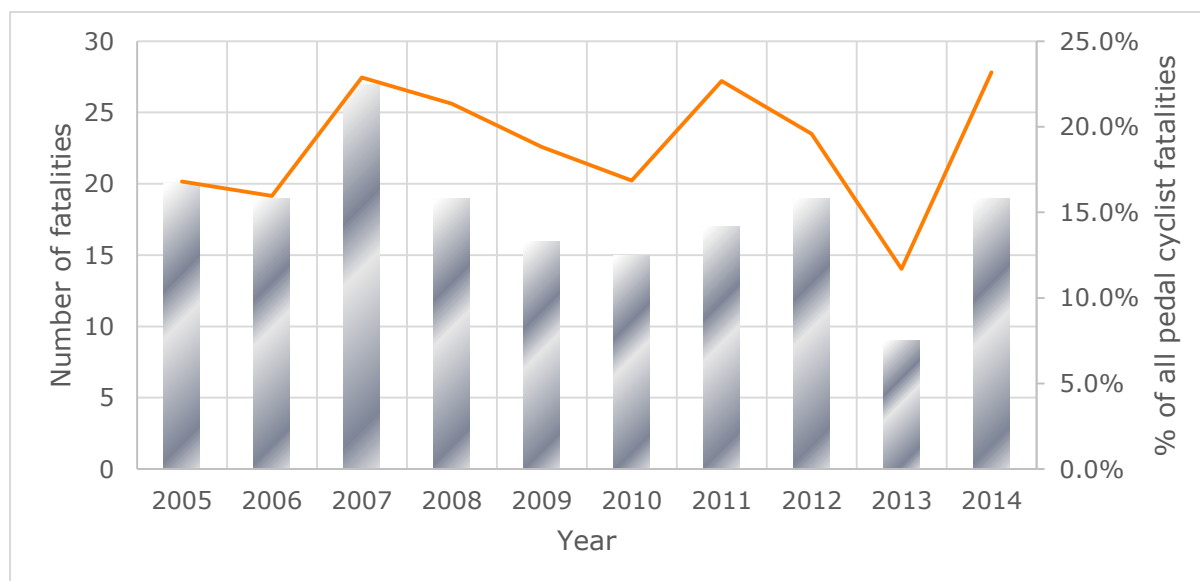
National data for Great Britain shows that pedal cyclists represented 11% of all casualties, a slightly lower proportion than for pedestrians. They represented 15% of all serious casualties and just fewer than 7% of all fatalities, both substantially lower proportions than for pedestrians. The detailed numbers are shown in Table A.5.

**Table A.5. GB pedal cycle casualties from accidents in 2014, by vehicle type structure.**  
**Source: Stats 19.**

Struck by vehicle type...			
	All vehicles	HGV >3.5t <7.5t	HGV ≥7.5t
<b>Fatal</b>	113 (100%)	1 (0.9%)	19 (16.8%)
<b>Serious</b>	3,401 (100%)	33 (1.0%)	56 (1.6%)
<b>Slight</b>	17,773 (100%)	133 (0.7%)	137 (0.8%)
<b>Total</b>	21,287 (100%)	167 (0.8%)	229 (1.1%)

Comparing to the pedestrian results shows the same pattern, but even more marked. Overall HGVs are under-involved in pedal cycle collisions in comparison to the fact they make up 5% of traffic in GB. However, HGVs of 7.5 tonnes and above are substantially over-represented in fatal collisions.

The main category of over-involvement has been studied in more depth and Figure A.5, below shows an analysis over time.



**Figure A.5. Trends in GB pedal cyclists killed in collision with an HGV ≥ 7.5 tonnes.**

There is no clear trend, suggesting that the underlying size of the problem has remained approximately constant but is subject to considerable random variation as would be expected with relatively low numbers. The long term average is 18 cyclists per year killed by HGVs in excess of 7.5 tonnes.

The impact point and pre-impact manoeuvre of the HGV when pedal cyclists are killed by vehicles in excess of 7.5 tonnes are shown in Table A.6.

**Table A.6. GB pedal cycle fatalities in accidents involving HGVs  $\geq$  7.5 tonnes divided by 1<sup>st</sup> point of impact and pre-impact manoeuvre for the HGV.**

**Source: Stats 19 years 2005-14 inclusive**

Vehicle Manoeuvre	1st point of impact					Total
	Unknown	Front	Back	Offside	Nearside	
Reversing	0	0	0	0	0	0
Parked	0	0	4	0	0	4
Waiting to go - held up	0	0	0	0	1	1
Slowing or stopping	0	0	0	0	2	2
Moving off	1	6	0	2	7	16
U-turn	0	0	0	0	0	0
Turning left	1	10	1	3	50	65
Waiting to turn left	0	0	0	0	0	0
Turning right	1	7	0	2	1	11
Waiting to turn right	0	0	0	0	0	0
Changing lane to left	0	0	0	0	0	0
Changing lane to right	0	0	0	0	3	3
Overtaking moving vehicle - offside	0	5	0	0	6	11
Overtaking static vehicle - offside	0	0	0	0	2	2
Overtaking - nearside	0	0	0	0	0	0
Going ahead left-hand bend	0	0	0	0	3	3
Going ahead right-hand bend	0	1	0	0	0	1
Going ahead other	6	28	0	5	21	60
<b>Total</b>	<b>9</b>	<b>57</b>	<b>5</b>	<b>12</b>	<b>96</b>	<b>179</b>

It can be seen that a left turn manoeuvre and a collision at the nearside of the HGV is the single largest group for GB pedal cyclists killed in collision with a large truck (28%). Another twelve percent are killed in collision with the nearside of an HGV that is just 'going ahead other'. Overall 9% of cyclists are killed when the HGV moves off from rest, though the impact points in these cases are distributed between nearside (4%), front (3%), and offside (1%). Six percent are killed when the HGV turns right, though most of these are in collision with the front of the vehicle. Similarly, 6% are killed when the HGV overtakes, though slightly counter-intuitively, half of these are in collision with the front of the HGV.

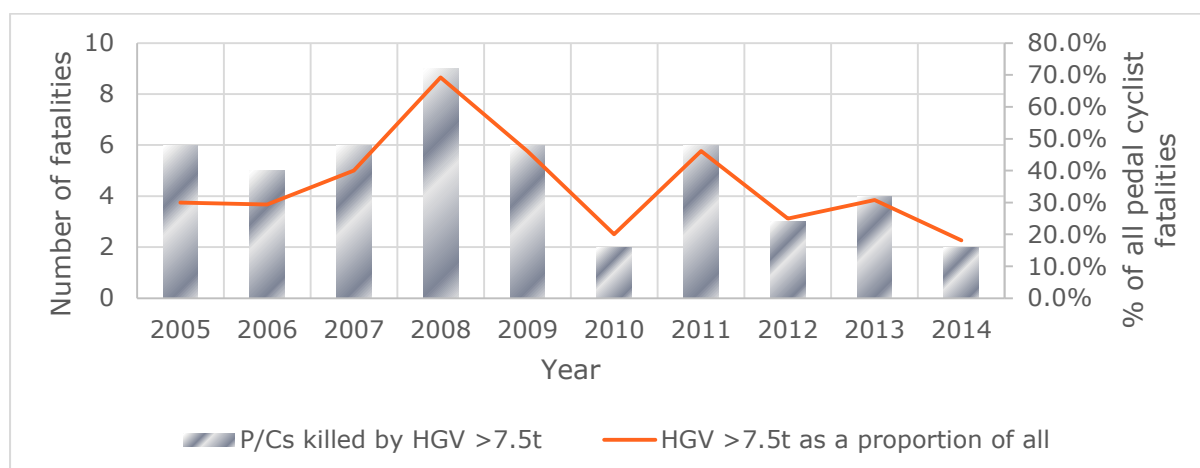
#### A.2.1.2 London

Equivalent figures for London have been based on Stats 19 data relating to collisions reported by the Metropolitan and City of London Police forces.

**Table A.7. GB pedal cycle casualties from accidents in 2014, by vehicle type structure.**  
**Source: Stats 19.**

Struck by vehicle type...			
	All vehicles	HGV >3.5t <7.5t	HGV ≥7.5t
<b>Fatal</b>	13 (100%)	0 (0.0%)	2 (15.4%)
<b>Serious</b>	420 (100%)	2 (0.5%)	6 (1.4%)
<b>Slight</b>	4,717 (100%)	58 (1.2%)	39 (0.8%)
<b>Total</b>	5,150 (100%)	60 (1.2%)	47 (0.9%)

It can be seen that the same patterns are repeated, under-involvement of HGVs relative to their traffic (4%) when all casualties are considered, over-involvement of larger trucks in fatal collisions. The over-involved crash type was investigated in more detail, with a trend analysis shown in Figure A.6, below.



**Figure A.6. Trends in London pedal cyclists killed in collision with an HGV ≥ 7.5 tonnes.**

Again, the trend over time is not completely clear, and is subject to considerable annual variation. There is some suggestion of a reduction from around 2008 or 9 but overall, it would be difficult to be confident that any apparent reduction was not merely random chance. The distribution of relevant crashes by impact point and manoeuvre are shown in Table A.8, below.

It can be seen that the largest group of fatalities (45%) are killed in collision with the nearside of the vehicle when it makes a left turn. A significant minority (16%) are killed when the HGV moves off from rest, around 8% in collision with the nearside and a further 4% in collision with the front. These groups all have the potential to be influenced by blind spots.

**Table A.8. London pedal cycle fatalities in accidents involving HGVs ≥ 7.5 tonnes divided by 1<sup>st</sup> point of impact and pre-impact manoeuvre for the HGV.**

Vehicle Manoeuvre	1st point of impact					Total
	Unknown	Front	Back	Offside	Nearside	
Reversing	0	0	0	0	0	0
Parked	0	0	0	0	0	0
Waiting to go - held up	0	0	0	0	0	0
Slowing or stopping	0	0	0	0	0	0
Moving off	1	2	0	1	4	8
U-turn	0	0	0	0	0	0
Turning left	1	1	1	1	22	26
Waiting to turn left	0	0	0	0	0	0
Turning right	1	1	0	1	0	3
Waiting to turn right	0	0	0	0	0	0
Changing lane to left	0	0	0	0	0	0
Changing lane to right	0	0	0	0	0	0
Overtaking moving vehicle - offside	0	0	0	0	0	0
Overtaking static vehicle - offside	0	0	0	0	0	0
Overtaking - nearside	0	0	0	0	0	0
Going ahead left-hand bend	0	0	0	0	2	2
Going ahead right-hand bend	0	1	0	0	0	1
Going ahead other	2	1	0	0	6	9
<b>Total</b>	<b>5</b>	<b>6</b>	<b>1</b>	<b>3</b>	<b>34</b>	<b>49</b>

For pedal cyclists killed in London, TfL were able to provide Stats 19 data linked to Vehicle Registration data to further categorise vehicle type. It was found that some heavy construction vehicles such as tippers or cement mixers were coded as “other motor vehicle” in Stats 19 and for the purposes of this analysis these should also be classified as HGVs > 7.5 tonnes. Including this data and spanning the years 2009 to 2014 gives the following results.

It can be seen in comparison to data presented earlier, including construction vehicles coded as ‘other motor vehicles’ does slightly increase the total number of cyclist fatalities identified and substantially increases the proportion of them that involved HGVs. The data also shows that in most years a very high proportion of the HGVs involved were construction vehicles. In comparison to the numbers of such vehicles registered (see for example (Delmonte, et al., Construction logistics and cycle safety: Technical Report, 2012) for London and (Cookson & Knight, 2010) for GB) this suggests considerable over-involvement in this type of crash.

**Table A.9. London pedal cyclist fatalities by HGV involvement**

Year	All cyclist fatalities	Number involving HGV	Number of HGVs that were construction or waste vehicles	% construction or waste
<b>2009</b>	13	9	2	22%
<b>2010</b>	10	4	3	75%
<b>2011</b>	16	9	7	78%
<b>2012</b>	14	5	1	20%
<b>2013</b>	14	9	7	78%
<b>2014</b>	13	5	4	80%
<b>Total</b>	<b>80</b>	<b>41</b>	<b>24</b>	<b>59%</b>

**A.2.2 Detailed characteristics of pedal cyclist crashes influenced by field of view**

(Talbot, Reed, Barnes, Thomas, & Christie, 2014) reviewed detailed police collision reports relating to 53 fatal or near fatal crashes involving pedal cyclists in London. Thirty-four of these cases involved a large vehicle, 30 of which were HGVs in excess of 3.5 tonnes. Seventy-four percent of these cases involved the pedal cyclist being run-over by the wheels of the HGV.

In 14 cases the HGV was turning left across the path of a pedal cyclist intending to travel straight ahead and a further two occurred when both the pedal cyclist and HGV were turning left. The research also identified several sub-groups within these crash types as well as assessing the possible influence of field of view across a range of different crash types. The crash types considered were sometimes structured in order to allow consideration of the relevance of things like infrastructure design, which are not directly relevant to direct vision. So, the results have been re-interpreted based on the descriptive text provided by (Talbot, Reed, Barnes, Thomas, & Christie, 2014) into categories of most relevance to direct vision standards. This has resulted in the information shown in Table A.10.

Although insufficient information was presented to allow the impact point to be defined rigidly for each category, where the impact point was recorded it was always either the front or nearside front of the HGV, i.e. the front corner. The report also suggested that the cyclists were usually run over by the front or rear wheels, though it did not quantify the frequency of each. In 2 cases, it was known that the cyclist intended to turn left at the same time as the truck turned left. In the remainder it is understood that the cyclist intended to travel straight on.



**Table A.10. Frequency of different types of pedal cyclist crash with relevance to front and side vision. Interpretation of data presented by (Talbot, Reed, Barnes, Thomas, & Christie, 2014)**

Manoeuvre	Sub-type	Number	Field of view contributory		Initial speed		Relative speed at impact
			Left	Front	Cyclist	Truck	
Turning Left	Setting off	4	1	3	Stationary	Stationary	Truck faster
	Cyclist undertaking on approach	6	6	0	Moving	Stationary or moving	Cyclist faster
	Cyclist undertake using pavement	3	3	0	Moving or stationary	Stationary	N/K
	Truck overtaking on approach	2	1	1	Moving	Moving	Truck faster
	Overtaking not clear	2	2	0	N/K	N/K	N/K
	Truck pulling out from side road in front of cyclist	1	0	0	Moving	Stationary	Cyclist faster
	All	18	13	4			
Both vehicles straight ahead	Cyclist undertaking	4	4	0	Moving	Stationary or moving	Cyclist faster
	Others	5	2	2	N/K	N/K	N/K
	All	9	6	2			
<b>Grand Total</b>		<b>27</b>	<b>19</b>	<b>6</b>			

(Jia & Cebon, A strategy for avoiding collisions between heavy goods vehicles and cyclists, 2015) Reconstructed nineteen police fatal accident reports relating to cyclists killed by a left turning HGV, nearly all in the Metropolitan Police area. Given the time frames reported it is possible that some of these cases are the same as those reported by (Talbot, Reed, Barnes, Thomas, & Christie, 2014). The reconstructions were undertaken as part of research efforts to develop a collision avoidance system that would allow trucks to avoid such crashes and the analysis was used to estimate the potential benefits of the system. Few details about the crashes were provided. As part of this direct vision project, Cambridge University provided more details of these

---

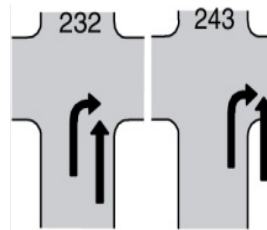
reconstructions based on extracts from a PhD thesis, including anonymised summary descriptions of 18 of the reconstructed collisions. It should be noted that the distribution of collision types is not necessarily representative of that seen in the collision statistics for London and reflects the sample selection strategy used to meet the Cambridge University's research goal.

These descriptions have been re-analysed to produce the following main conclusions:

- 9 of the 18 cases involved a 4 axle rigid construction vehicle, 5 involved other smaller rigid vehicles and another 4 involved articulated vehicles (including 1 articulated tipper). Although small, the sample is thought to be broadly representative of current statistics;
- 10 of the 18 cases occurred at cross roads, 5 at a T-junction where the HGV was turning from the main road into the side road, 2 were at a roundabout and one at a complex junction.
- 13 of the 18 cases involved junctions controlled by traffic lights and in all but 1 of these cases the lights turned from red to green just before the collision. All but 1 of the collisions at cross roads were at traffic light controlled cross roads;
- 14 of the 18 left turn cases involved the cyclist carrying straight on. There were 4 cases of both vehicles turning left at the same time;
- The angle of the turn needed for the HGV to negotiate the junction was between 65 and 135 degrees but just over half (10 of the 18) had an angle between 80 and 100 degrees.
- The collisions could be classified in more detail in 13 cases:
  - Both vehicles stationary before moving off together: 4 cases
  - Moving cyclist approaches stationary HGV from behind as it moved off: 5 cases
  - Both vehicles moving before collision: 4 cases
- In 11 cases, the pedal cyclist was assessed as undertaking the HGV (moving up its inside) and in 2 cases the HGV was considered to be overtaking the cyclist before turning. In one case, both vehicles were consistently alongside one another. There were 4 unknowns.
- 12 collisions occurred at the nearside front, 3 in the centre of the nearside and 1 at the rear, with two unknowns.
- Of those that occurred at the NSF, three were ahead of the front axle, 8 were in line with or just behind the front axle.
- All of the pedal cyclists were run over by the axles. Which axle was unknown in 4 cases, the front axle in 1 case, the second front axle (axle 2 of 4 in classic tipper configuration) in 3 cases, leading axle of semi-trailer group in 2 cases, and the rearmost axle in 8 cases.

(Schreck & Seiniger, 2014) have also studied similar accidents in detail in Germany. They studied in-depth data from both an insurance claims database and the German In

Depth Accident Study (GIDAS). A comprehensive system of crash type coding was used in their data (Bast & GDV, 2003) that creates hundreds of distinct crash types. They found that for goods vehicles in excess of 7.5 tonnes, 88% of crashes occurred in just two types as illustrated below.



**Figure A.7. Main crash types in crashes between a turning truck (>7.5t) and a cyclist.**

**Source: (Schreck & Seiniger, 2014)**

Essentially this supports the findings of (Knowles, Smith, Cuerden, & Delmonte, 2012) and (Jia, 2015) that most crashes involved the cyclist travelling straight ahead. One slight difference is that accident type 243 appears to suggest that the cyclist may have been travelling on the pavement before the collision but the report implies that this can include a separated cycle lane. They also found that the vast majority of crashes occurred in daylight and dry conditions.

The insurer data categorised crashes according to speed and lateral distance between the parties. They found that where the bend was less than 90 degrees, speeds tended to be higher and lateral separations lower (c.1m). With tight turns, the lateral separation depended on speed and whether or not the vehicle swung out left before making the right turn (equivalent to swinging right before a left turn in UK). At lower speeds without swing out, lateral separations were up to 2m, at higher speeds or with swing out, the lateral separation increased to between 2 and 5m.

The German data (Schreck & Seiniger, 2014) identified that around 60% of the right turn collisions occurred at traffic light controlled junctions (58% insurer, 61% GIDAS) but the insurer data suggested only a small proportion of all the goods vehicles (22%) made a traffic related stop before the turning manoeuvre. However, this contrasts with data from another German Study (Dekra, 2014) that was cited by (Schreck & Seiniger, 2014), which found that between 50% and 88% of vehicles were stationary before turning.

It was also found that most of the HGV drivers did not perform an identifiable braking manoeuvre before collision (90% of insurer cases and 70% of GIDAS).

The relative speed between vehicles was typically unknown in the German insurer database but the HGV speed was most commonly (69% of cases where speed was known) found to be less than 20 km/h. The GIDAS data contained data on the speed of both parties. It was found that in 90% of cases the HGV speed was less than 30 km/h and the speed of the pedal cycle was less than 20 km/h in 85% of cases. In 40 % of cases the initial speed of the cyclist exceeded that of the HGV such that it was 'undertaking' the HGV.

The insurer data found that in Germany, just 5% of the cyclists killed in right turn collisions with a large truck involved a tipping vehicle. The most common vehicle (29%)

was an articulated tractor semi-trailer vehicle. This is in strong contrast to GB and London figures. The reason for the difference is unknown but could be a function of different vehicle usage patterns in German cities compared with UK.

Another strong contrast with the findings in GB was that in the German data it was found that 91% of cyclists were travelling 'alongside the road' and only 9% on the carriageway. This was followed by a note that:

*"However, it cannot be deduced from this, and applied to the entire territory of the Federal Republic of Germany, that cycle tracks alongside roads are more problematic. It may also reflect a higher number of cycle tracks and/or a high intensity of use in Dresden and Hanover."*

Figure A.8 shows an example of separated cycle lanes and possible visual obstructions that was shown in the report.



**Figure A.8. Examples of separated cycle lanes with potential line of sight obstruction in Germany. Source (Schreck & Seiniger, 2014)**

### A.3 Importance of other crash types

Pedestrian and pedal cyclist fatalities represent about a third of fatalities involving HGVs in GB. Crashes with blind spots as a contributory factor can occur with other vehicle types, for example, side swipes with cars during lane changes, or pulling out in front of motorcycles or small cars while hidden in the mirror or A-pillar blind spot at roundabouts etc.

Stats 19 includes a system of contributory factors which are completed by the reporting police officer within a short time of the collision occurring. Consultation with qualified Metropolitan Police Collision Investigators suggested that the judgements were rarely informed by the conclusions of their detailed and qualified investigations and they had reviewed a sample of cases and found that in technical cases they were often incorrect. Thus, statistics should be treated with caution. However, analysis of the data available up to 2013 showed 5,696 casualties from accidents involving an HGV>7.5t where a vehicle blind spot has been assigned as a contributory factor. When all casualty

severities were considered, 84% of these related to car occupant casualties. When only fatalities were considered 90% related to pedestrians and pedal cyclists.

Although caution is required because of the technical limitations in the contributory factor data, this suggests that blind spot crashes with road users other than pedestrians and pedal cyclists can be frequent, but they rarely result in fatalities.

When designing new test procedures, it is always important to consider unintended consequences. It is possible that by providing an incentive for vehicle manufacturers to change their design to improve the view of vulnerable road users in close proximity, the design change chosen could inadvertently restrict the view of other road users in certain circumstance, or even affect an unrelated aspect of safety, for example the crashworthiness of the cab. Such unintended consequences could have an adverse effect on other areas of safety such that vulnerable road user casualties from manoeuvring collisions decrease but another casualty group increases. Currently, field of view restrictions do not appear to cause substantial numbers of fatalities in right turn collisions or in junction crashes with cars, which leads to the conclusions that a field of view standard is not required in areas relevant to those manoeuvres. However, if such a standard is not considered it is possible that design changes could have adverse effects in these areas.

#### A.4 Summary of crash data

The in-depth data studied previously showed that vehicle blind spots were likely to be a contributory factor in accidents where vehicles were turning and moving off. The number of pedestrian and pedal cyclists killed in such collisions is summarised for GB in Table A.11, below and for London in Table A.12, below.

**Table A.11. Summary of GB VRU fatalities relevant to direct vision**

VRU Type	HGV Manoeuvre	1st point of impact (HGV)		
		Nearside	Front	Offside
Pedestrian	Moving off	0.9	7.7	0.2
	Turning left	1.7	1.1	0.1
	Turning Right	0.3	0.8	0.2
	Not vision relevant	6.7	26.6	1.4
Pedal Cyclists	Moving off	0.7	0.6	0.2
	Turning left	5	1	0.3
	Turning Right	0.1	0.7	0.2
	Not vision relevant	3.8	3.4	0.5
All	Not vision relevant	10.5	30	1.9
	Vision Relevant	8.7	11.9	1.2
	Weighting (VR)	39.9%	54.6%	5.5%

**Table A.12. Summary of London VRU fatalities relevant to direct vision**

VRU Type	HGV Manoeuvre	1st point of impact (HGV)		
		Nearside	Front	Offside
Pedestrian	Moving off	0.4	2.1	0.1
	Turning left	0.5	0.2	0.1
	Turning Right	0	0.1	0.1
	Not vision relevant	0.9	2.5	0.3
Pedal Cyclists	Moving off	0.4	0.2	0.1
	Turning left	2.2	0.1	0.1
	Turning Right	0	0.1	0.1
	Not vision relevant	0.8	0.2	0
All	Not vision relevant	1.7	2.7	0.3
	Vision Relevant	3.5	2.8	0.6
	Weighting (VR)	50.7%	40.6%	8.7%

Thus, the total numbers of fatalities involved (c. 22/year in GB and c. 7/year in London) can be used to inform the development of a business case to assess the cost effectiveness of measures (not part of this project). It should be noted that for this purpose, construction bodied vehicles coded in stats 19 as 'other motor vehicles' should be added to the totals and may increase them quite substantially.

This accident type is not only a London or GB phenomenon, for example, (Schreck & Seiniger, 2014) show estimates that 23 cyclists were killed in Germany in similar turning manoeuvres. This represents 6% of all cyclist fatalities in Germany, which is very similar to the equivalent figure for GB (c.7%) but much lower than the figure for London where 19% of all pedal cyclist fatalities involve an HGV of 7.5t or more turning left. Pedestrians killed by HGVs when moving off from rest were also identified as a significant group of fatalities in Japan (MLIT, 2015), though slightly less so than in the GB data.

The distribution of relevant cases around the different impact points can be used to inform the ranking of the importance of different areas within the field of view assessment developed. In this case, inclusion of relevant vehicles coded as 'other motor vehicles' is only important if their involvement in 'moving off' and 'turning right' collisions is different to the turning left cases identified. There is evidence to suggest such vehicles are over-involved in many crash types (see for example Cookson & Knight, 2010) but undertaking additional investigation using data not currently available to the project team would increase confidence in that conclusion.

It can be seen that the importance of different areas around the vehicle varies depending on whether only London is considered or the whole of GB. In London, the nearside of the vehicle is the most important, whereas if GB as a whole is considered then the front is the most important.

---

## A.5 Defining the critical areas for direct vision from HGVs

### A.5.1 Moving off scenarios

In order to avoid a crash with a pedestrian while pulling away from rest, the driver would need to be able to see the pedestrian and recognise the threat that a collision with them presented at a time that would be sufficient to allow them to react and avoid the collision. This reaction time will in most cases simply be a decision time because the decision will be to not take any action, which is to not pull away from rest. Research on reaction time varies considerably but a range of between 0.75 and 1.5 seconds would cover a wide range of authors' estimates and different circumstances. Using this full range therefore represents a "worst case" because the research is based on a need to take action. However, in these circumstances only a decision not to act is required which would tend to reduce the necessary reaction time. Defining the field of view requires estimates of the following parameters at the critical time before collision:

- Crossing path, e.g. straight across perpendicular to the kerb, or leaving kerb at a point behind (or in front of) the front of the vehicle, walking diagonally to the front corner of the vehicle.
- Lateral position of the pedestrian relative to the vehicle
- Longitudinal position of the pedestrian relative to the vehicle
- Height of the pedestrian;
- Proportion of pedestrian that must be visible to ensure quick and accurate recognition of the collision threat posed

In terms of the field of view required to see them at the critical moment, the worst case lateral position of the pedestrian would be based on an assumption that the pedestrian was walking from the nearside or offside and the impact took place at the extreme edge of the vehicle. A variety of studies have measured walking speed of pedestrians crossing the road. (Gates, Noyce, Bill, & Van Ee, 2006) found that the mean speed for adults aged 30 to 64 was 5.2 km/h (1.44m/s) which reduced to a mean speed of 4.2 km/h (1.16 m/s) for a group aged 65 and over. The 85<sup>th</sup> percentile value for the over 65 group<sup>10</sup> was also 5.2 km/h. Selecting the value of 5.2 km/h means that the fastest 15% of over 65's and the fastest 50% of 30-64 year olds who were walking would not be covered in impacts at the outermost edges of the vehicle. Given the worst case nature of the scenario with the contact occurring at the extreme edge of the vehicle, this seems reasonable; and also, given that these faster individuals are more likely to be able to get out of the way quickly (or stop moving towards the vehicle) when the vehicle revs up or begins to move. Although it should be noted that walking pace would be the best case for determining this dimension, i.e. it is the slowest a vulnerable road user is likely to be travelling.

If the pedestrian crossed the road perpendicularly, then this would mean that for a reaction time between 0.75s and 1.5s, the pedestrian would be between 1.1m and 2.2m

---

<sup>10</sup> Data was not available for over 75's



outside the outer edge of the vehicle at the moment the driver needed to see them with time to process the information and abort the intended pull away manoeuvre before they entered the path of the vehicle.

No information has been identified that objectively quantifies how close those people killed in these circumstances were to the front of the vehicle when they crossed. In the absence of such objective information it has been assumed that pedestrians will cross very close to the vehicle such that a gap of just 15 cm exists between the point of the body closest to the vehicle and the leading edge of the vehicle. For a 5<sup>th</sup> percentile female, anthropometric data<sup>11</sup> suggests the widest point is the hips and that the outer edge would be 15 cm from the centreline of the body. Thus, in a relatively extreme case (though not quite the worst case), the centre of the top of the head would be approximately 30 cm from the front of the HGV.

If it was assumed that the pedestrian left the kerb at a point behind the front of the vehicle and walked diagonally at 45 degrees to reach a crossing point where the body centreline was 30 cm ahead of the vehicle, then the point at which they would need to be seen would be between 0.78m and 1.56m laterally from the outer edges of the vehicle and between 0.48m and 1.26m back from the front of the vehicle.

A 5<sup>th</sup> percentile female at 149 cm tall would represent close to the worst case from the point of view of pedestrian height identified in accident data.

The pedestrians are most important casualty group in this scenario but the evidence also shows that the forward view is relevant to some cyclist cases, particularly those where cyclists manoeuvre around a stationary HGV to position themselves in front of it, for example at an Advanced Stop Line. Anthropometric data suggested that the saddle height of a bicycle for a small female was around 0.87m. If the back was vertical, it would be expected that the top of a small female head when seated on the bike would be around 1.65m. This is slightly higher than the standing position but this is because at an ideal saddle height you cannot place both feet flat on the floor. In reality, there may be a lean to the side to allow one foot to be flat on the floor. This would reduce height to approximately the stature of 149 cm. There would probably also be a lean forward as well such that the hands remain on the handlebars. If a back angle of 30 degrees to the vertical were assumed this would reduce height to around 1.39m. Although lower than the height of a pedestrian, this would necessarily be further forward. Even if the rear wheel were touching the front bumper of a truck, the head would be positioned part way between the saddle and handlebars of the bike, around 1m or more forward of the front of the truck. Thus, the pedestrian standing very close to the vehicle is still likely to represent the worst case.

Similarly, no objective information has been identified that assesses correct detection rate or speed based on the proportion of a person that is visible at the edge of a windscreen area. It is clear that if only a 1 cm slice of the top of the head is visible, the chances of detection would be not much better than zero. It is equally clear that seeing the whole height of the person would maximise the chances of fast and correct detection. However, it is also likely that the relationship between the proportion seen and the

---

<sup>11</sup> <http://msis.jsc.nasa.gov/sections/section03.htm>

chances of detection will not be linear. Increasing the view from 1 cm from the top of the head to 30 cm from the top of the head (which would probably cover the full head and top of the shoulders) would have a very large effect in increasing detection. However, if the knees of the pedestrian were already visible, increasing the view a further 30 cm such that the feet were visible would have a much smaller effect on fast successful detection.

In the absence of research to objectively quantify the non-linearity of this relationship, it has been assumed that the maximum detection rate and minimum detection time would be reached when the centre-line of the body can be seen from the top of the head down to the waist, which for 5<sup>th</sup> percentile females would be positioned approximately 93 cm from the floor.

This would effectively form a lower boundary to a field of view zone in front of the vehicle. As far as vulnerable road users are concerned there is little merit in rewarding a view above the horizon so it is worth also considering an upper boundary.

At the front of the vehicle this could be represented by considering there to be little merit in seeing over the top of the head of a 95<sup>th</sup> percentile male (c.1.9m) positioned far enough away that they could cross the road and clear the far side of the vehicle in less than the time it takes the vehicle to reach them. At 5 km/h it would take a typical adult about 2.5 seconds to fully cross a 3.5m lane width. At urban speeds of 30 mile/h, a vehicle would travel almost 34m during this time. There would, therefore, be no benefit to vulnerable road users in HGV drivers being able to see points above 1.9m at a distance of 34m from the front of the vehicle.

#### **A.5.2 Left turn scenarios**

When the lower boundary of vertical angle of view is considered, the situation for left turn crashes is similar to that for the moving off scenario:

- A small proportion of cyclists were initially positioned in blind spots in front of HGVs (at advanced stop lines) that collided with them when they turned left. Based on the same approach, making a 5<sup>th</sup> percentile female, immediately in front of the vehicle visible to approximately waist height would require visibility of a point approximately 0.93m high at a position approximately 1 m ahead of the vehicle.
- Similarly, a cyclist or pedestrian at the side of the vehicle could be positioned very close. Taking the same approach as for "moving off" and assuming no further benefits were derived from seeing parts of the cyclist below saddle height suggests visibility is needed of a point 0.93m high and 0.3m from the edge of the vehicle.

Consideration of the horizontal angle is relatively simple for the front of the vehicle, the cycle could be positioned anywhere and therefore, the view should extend beyond the full width of the front of the vehicle.

For the side of the vehicle, the horizontal angle of view required is considerably more complex. It is defined by the starting positions of each vehicle, their relative speed and the time the driver requires to recognise the danger and react accordingly to avoid a

collision, or if the collision cannot be avoided, to avoid running over the cyclist to minimise the chances of serious injury. As such, it varies considerably with crash circumstances. The in-depth data (Talbot, Reed, Barnes, Thomas, & Christie, 2014), (Jia, 2015), (Schreck & Seiniger, 2014) allowed the identification of several broad collision scenarios:

- 1) Cycle moves up the inside of a stationary HGV that then moves off to turn left - these collisions are characterised by large initial differences in speed with the cyclist initially moving faster than the truck. As such, the relative position of the cyclist changes substantially during the manoeuvre, though the impact point tends to be at the front, from just behind the front axle to the front corner. The different data sources vary but this tends to be the single most frequent category of collision (40% of GIDAS & (Jia, 2015), 70% (Talbot, et al., 2014).
- 2) Both vehicles move off from rest together – these collisions are characterised by small differences in vehicle speeds, truck slightly overtaking or cyclist slightly undertaking, depending on initial position. Thus the position of the cyclist relative to the truck will vary by only fairly small amounts during the manoeuvre, such that initial position will be quite close to impact point, most frequently at the nearside front in the zone from just behind the 1<sup>st</sup> axle to the front nearside corner.
- 3) Both vehicles moving – again, relative speeds in this situation are low and truck could be overtaking cyclist, cyclist undertaking slow truck or moving in parallel together in traffic. However, the starting positions are more variable from front to rear and as a result impact points can be anywhere along the side, as far back as the rear axle of an articulated vehicle.

In Scenario 1 and 2, the longitudinal position of the cyclist relative to the truck is much less likely to vary by a large amount. As such, the position of the cyclist relative to the truck, at the time before collision that the driver needs to see them in order to avoid collision, will not vary so much from the final impact points. Therefore, considering horizontal angle of view required can legitimately be based on information regarding initial position and impact point. In scenario 1, there is evidence to suggest a starting position ranging from near the front of the vehicle to just ahead of the vehicle as well as evidence that cyclist may be positioned directly in front of the vehicle. It is, therefore, considered that the required view would join that of the front zone such that the requirement to see a point 0.93m high, 1m ahead of the vehicle, across the full width of the vehicle extends horizontally to a distance 0.3m outside the outer edges of the vehicle. Impact points to the rear of the position of axle 2 of 4 on a traditional 32 tonne tipper were relatively rare. So, it has been assumed that visibility of the cyclist would be beneficial back as far as the mid-point between the two front axles of a traditional 4 axle N<sub>3</sub>G tipper<sup>12</sup>, which is approximately 2.5m to the rear of the foremost point of the vehicle.

In scenario 2, the forward considerations would be the same. However, the zone could extend back as far as the rear axles of the vehicle, based on the impact points. Again,

---

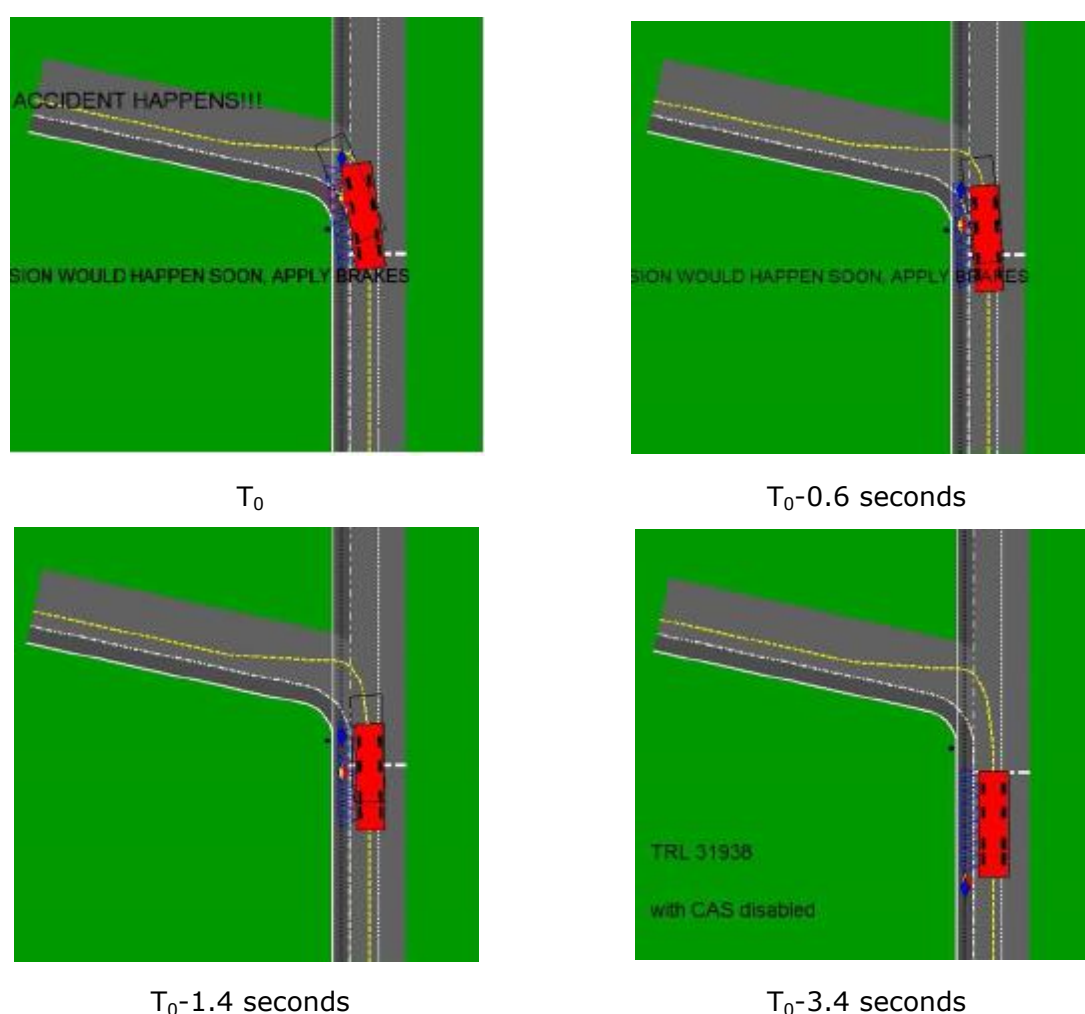
<sup>12</sup> Based on a Volvo example from

[http://segotn12827.rds.volvo.com/STPIFiles/Volvo/ModelRange/fm84fr1ctx\\_gbr\\_eng.pdf](http://segotn12827.rds.volvo.com/STPIFiles/Volvo/ModelRange/fm84fr1ctx_gbr_eng.pdf)

for the most commonly involved 32 tonne tipper this could be 8.5m to the rear of the front of the vehicle.

Scenario 3 is more complex and dynamic, with the position of the cyclist relative to the truck changing more quickly during the time leading up to the collision. Estimates in two different sources give different results but in combination suggest around 50% of cyclists killed by HGVs in left turn manoeuvres are of this type.

Cambridge University ran computer simulations of the left-turn fatal accidents they had studied, with the aim of identifying the potential for a collision avoidance system to prevent this type of accident. Illustrations of the results of one such simulation were provided to TRL and are reproduced in Figure A.9, below.



**Figure A.9. Simulation of a real-world fatal collision involving a cyclist and a left turning HGV in circumstances consistent with scenario 3. Source: (Jia, Developing a collision avoidance system for left-turning trucks, 2015)**

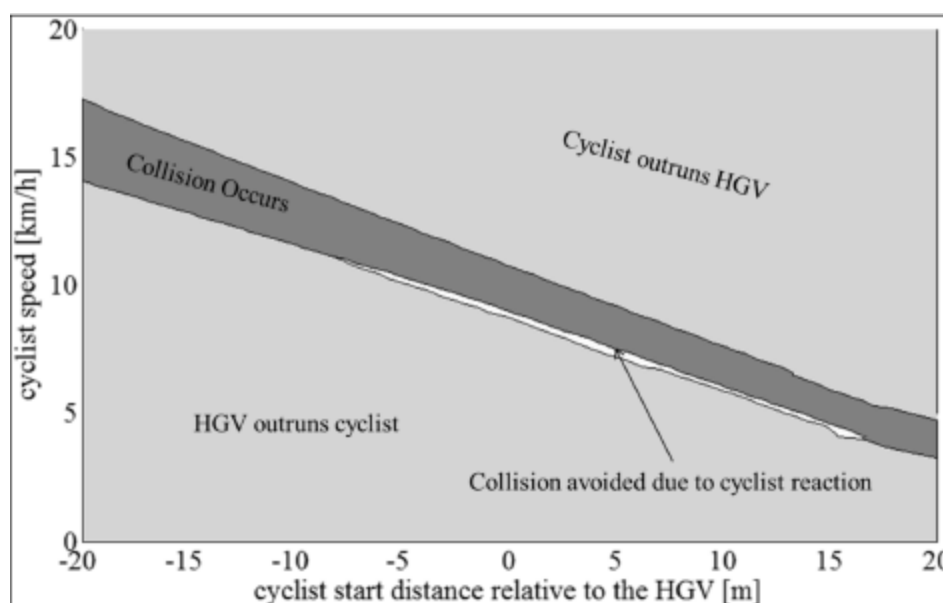
In this collision, the HGV moved off from rest when traffic lights ahead turned green. The cyclist was initially positioned at the rear of the vehicle but was moving more quickly

than the HGV and moved up the inside. The sequence of images progresses backwards from the collision point, from left to right then down a line, in irregular time steps.

It can be seen that at intervals slightly shorter than typical reaction times (0.6 seconds and 1.4 seconds compared with 0.75 seconds and 1.5 seconds) the cyclist was just ahead of and just behind the second axle, respectively. This is very approximately equivalent to a position between around 3 and 4m rear of the front of the vehicle. This resulted in a fairly typical impact point around half way between the two front axles.

In this simulation the relative speed of the cyclist to the truck was fairly small just before collision (10 mile/h for the cyclist compared with 8 mile/h for the truck). A higher relative speed for the cyclist would be expected to place them further back at the moment of critical reaction times

(Jia & Cebon, 2015) undertook a parametric study considering a range of different cyclist speeds with a fixed truck speed of 10 km/h. In the strict sense, this is representative of scenario 2 because both vehicles were moving from the start but where the cyclist speed is higher than the truck, the dynamics near the moment of impact would be similar to scenario 3. The results are shown in Figure A.10, below.



**Figure A.10. Results of a parametric study of the outcome of a range of conflicts between a cycle travelling straight on and an HGV turning left, given a range of different starting positions and cycle speeds. Source (Jia & Cebon, A strategy for avoiding collisions between heavy goods vehicles and cyclists, 2015)**

The distance on the x-axis was defined as the distance between the front of the pedal cycle and the rear of the HGV at the start of the simulation significantly before commencement of the left turn. Negative values indicate that the cyclist started behind the rear of the HGV. In all simulations, the HGV was travelling at 10 km/h. It can be seen that collisions only occur in a fairly narrow band of cyclist speeds. Where the cycle starts a long way behind the truck (-20m) the cyclist has to be travelling fast (around 14 to 17 km/h) in order for a collision to occur. Where the cyclist starts 20 m ahead of the rear of the vehicle (so quite some distance in front of the front of the vehicle), the cyclist

must be travelling slowly for a collision to occur, between around 4 or 5 km/h. This means that in all the configurations simulated there was always less than 7 km/h difference in the speed of the two vehicles.

The relative positions of cyclist and truck at the critical moment can be calculated for a collision of scenario 3, where the relative speed of the cyclist was up to approximately 7 km/h greater than the HGV over the final moments before collision. This speed was chosen because a higher relative speed will produce a 'worst case' from a direct vision point of view, that is, the cyclist will be the furthest back from the cab that they could be at the moment a driver would need to identify a collision risk and react accordingly to avoid collision. The impact point was assumed to be half way between axle 1 and axle 2, as was found to be common in the in-depth collision data. In such circumstances, then the position of the cyclist 0.75 seconds and 1.5 seconds before collision would have been approximately 4m and 5.4m rear of the front of the vehicle.

Based on these analyses, then if direct vision were to have a chance of avoiding these collisions, then a point 0.93m from the ground and 0.3m from the side of the HGV would need to be visible at positions of approximately:

- 2.5m rearward of the foremost point of the vehicle for collisions of scenario 1
- 5.4m rearward of the foremost point of the vehicle for collisions of scenario 3
- 8.5m rearward of the foremost point of the vehicle for collisions of scenario 2

In some collisions, the impact point was close to the axle that ran the victim over. For example accidents where the impact point was in the region of the front axle and the victim was runover by the second front axle, or collisions where the impact point was along the sideguards of a trailer and they were run over by the leading trailer axle. In these cases, at typical speeds of 10 to 16 km/h, the runover event would be expected to occur somewhere in the region of 0.5 to 0.8 seconds after initial impact. In these cases, given the typically small differences in speeds between cyclists and HGVs, the position of the cyclist would be only slightly further forward than reported above.

However, it was more common for impact points to be around axle 1 or 2 and for the victim to be runover by axles 3 or 4, a separation of up to around 7m, representing an elapsed time of up to around 1.6 seconds. From a speed of 16 km/h, a truck can stop in less than 1 second, meaning the driver would need to become aware of the cyclist somewhere between 0.15s and 0.9s before impact. At this time most cyclists will be in a position forward of the second front axle, approximately 3.5m rear of the foremost point of the vehicle.

All of the above points could be considered candidates for positions of the lower boundary of a field of view. As far as vulnerable road users are concerned there is little merit in rewarding a view above the horizon so it is worth also considering an upper boundary.

At the side of the vehicle this could be represented by considering there to be little merit in seeing over the top of the head of a 95<sup>th</sup> percentile male (c.1.9m) positioned approximately 5m from the side of the vehicle as found to be the typical maximum lateral separation by (Schreck & Seiniger, 2014).

---

(Schreck & Seiniger, 2014) defined the relevant zone for right turn collisions to be up to 5m laterally from the side of the vehicle and from the front of the vehicle to 6m rear of the front.

### ***A.5.3 Defining the view required for normal driving***

In the absence of specific data on problems and considering the fact that analysing every conceivable collision scenario would be very difficult, a simple approach has been taken to the consideration of a field of view required for normal driving, based on the principles defined during the development of visibility test procedures for passenger cars as possible candidates for inclusion in consumer test programmes (Knight, Grover, Brook-Carter, Dodd, Clift, & Cherry, 2005). This research undertook analyses of accidents in order to define the relative headings of vehicles in two vehicle crashes. Road geometry guidelines were studied in order to define the position of vehicles at critical times during the decision process at junctions. Videos taken from the driving position were analysed to identify where relevant information was positioned in real road scenes and, finally, guidelines relating to the size, visibility and location of road signs were assessed. This led to a conclusion that in the horizontal plane, the whole forward 180 degree field of view from the driver's eyes was equally important and related to the main forward control tasks of driving the vehicle. The rearward 180 degrees was relevant more to collisions in low speed manoeuvring.

On this basis, the view required for normal driving of HGVs will be considered to be the same forward 180 degrees. However, the vertical angles considered relevant in the previous research (10 degrees up to 6 degrees down from horizontal, centred on the drivers eyes) will be different because of the substantial difference in the eye-positions of car drivers compared to truck drivers.

In their comparison of the field of view from 19 different designs of HGV (Summerskill, Marshall, Paterson, & Reed, 2015) defined an upward limit to the field of view considered necessary of 7 degrees from the driver's eye point. This was, in turn derived from a minimum requirement contained in UN Regulation 125. This regulation applies only to M1 category vehicles (passenger cars) and so there is no guarantee that HGVs will give the same minimum view.

Overhead Gantry signs on motorways will have a minimum of 5.2m ground clearance to ensure that they cannot be struck by the tallest trucks such that the top edge might be in the region of 6.4m from the ground. The Regulatory requirements for cars have been extended to trucks on the basis that the distance at which such a sign must still be visible is the same in each vehicle type. The actual heights visible at different distances have been calculated. The results are shown in Table A.13.



**Table A.13. Consideration of visible heights and angles for different truck heights based on different measures of equivalence to car regulations.**

Scenario	Vehicle type	Eye height (m)	Max upward angle visible from eyes (deg)	Max height (m) visible at forward distance (m) of				
				2	5	10	20	40
UN R129 Minimum	Car	1.5	7.0	1.7	2.1	2.7	4.0	6.4
Close equivalent for truck	Low truck	1.97	6.3	2.2	2.5	3.1	4.2	6.4
	High truck	2.84	5.1	3.0	3.3	3.7	4.6	6.4
Low truck equivalent to high truck at 5m		1.97	14.9	2.5	3.3	4.6	7.3	12.6
Low truck equivalent to high truck at 2m		1.97	27.2	3.0	4.5	7.1	12.3	22.6

Being able to see an overhead gantry at motorway speeds when close enough to read the text could be considered essential and appears broadly consistent with the regulatory minimum standard of view.

Being able to see a traffic signal located close to the front of the vehicle would also be considered very desirable, though perhaps not essential because in most circumstances there is a requirement for a secondary signal to be positioned further back from the driver<sup>13</sup>. The primary signal must be at least 1m beyond stop line so probably at least two m from driver eye point. The height of the signal head is not controlled by the standard but could be expected to be at least 3m tall. In this case, a low truck with an upward view at an angle equivalent to the regulatory standard for cars, based on visibility of a gantry sign, might not be able to see even a signal at the lower end of the range if only 2m distant.

If it was considered necessary for the close range performance of a low truck to be equivalent to a high truck at close range, then the angle of view would need to be increased substantially, which would result in considerable additional view that offered little benefit at longer distances.

<sup>13</sup> <http://www.standardsforhighways.co.uk/dmrb/vol6/section2/td5004.pdf>

---

## Appendix B Review of existing procedures

Appendix B provides a review of the available literature describing the testing procedures and assessment criteria underpinning the evaluation of direct and indirect fields of view for vehicle drivers. Each section provides a summary report on the relevant literature, before critically appraising the adopted procedural approach by providing a short commentary on the advantages, disadvantages and any future recommendations.

### B.1 CLOCS/LDS-2015 and UMTRI-2005-30

#### B.1.1 Summary

The CLOCS/LDS-2015 method was developed by Loughborough Design School (LDS) for TfL's CLOCS programme in 2015. It was designed to compare the direct and indirect FOV between the best-selling HGVs in London. The method is partially based on previous work for PNCAP.

A CAD-based driver vision assessment is performed using 3D scans of HGV cabs. The authors note that manufacturer CAD models could be a suitable alternative to 3D scans. Direct and indirect vision are assessed using the same volumetric projection procedure.

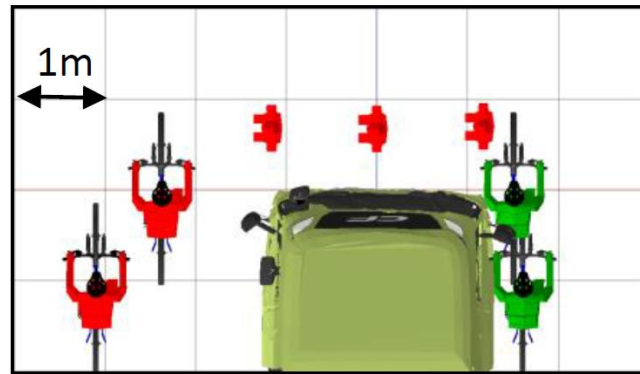
The best-selling cab height was used for the assessment after it was found that using a best case (lowest cab) and worst case (highest cab) was not sufficiently representative of the actual on-road situation.

The UMTRI-2005-30 Eyellipse and Seating Accommodation Model for Trucks and Buses (Reed M. P., 2005) is used to define seat fore-aft, steering wheel position and eyellipses for a 5<sup>th</sup>, 50<sup>th</sup> and 95<sup>th</sup>-percentile driver. The centres of these eyellipses are used for binocular vision projections. The UMTRI-2005-30 method required some manufacturer-provided vehicle measurements with regard to the driver's accelerator heel point.

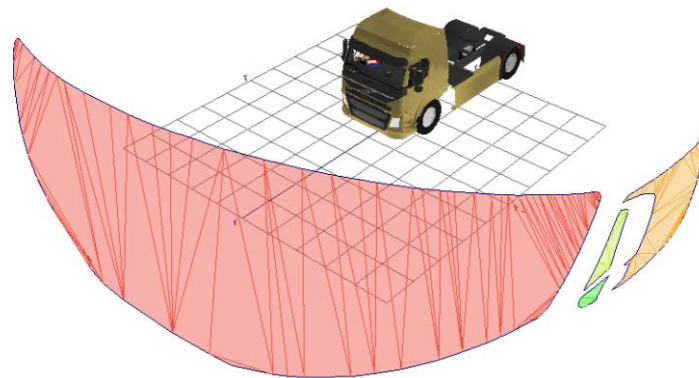
The assessment procedure focuses on direct and indirect visibility in three areas adjacent to the cab: Front, left and right. These areas were chosen to represent the zones where the majority of fatalities occur.

The assessment is based on two quantitative criteria:

- VRU obscuration distances at defined positions in frontal (3 positions, 50<sup>th</sup> percentile male pedestrians), nearside (2 positions, 50<sup>th</sup> percentile male cyclists) and offside (2 positions, 50<sup>th</sup> percentile male cyclists) positions. See Figure B.1.
- Area of window projections onto a sphere with a vertical clipping applied to not incentivise areas of vision that provide no safety benefit. See Figure B.2.

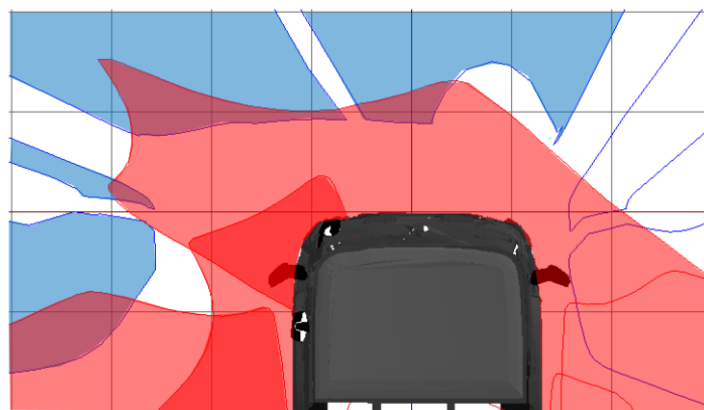


**Figure B.1. VRU obscuration distance diagram (Summerskill, Marshall, Paterson, & Reed, 2015)**

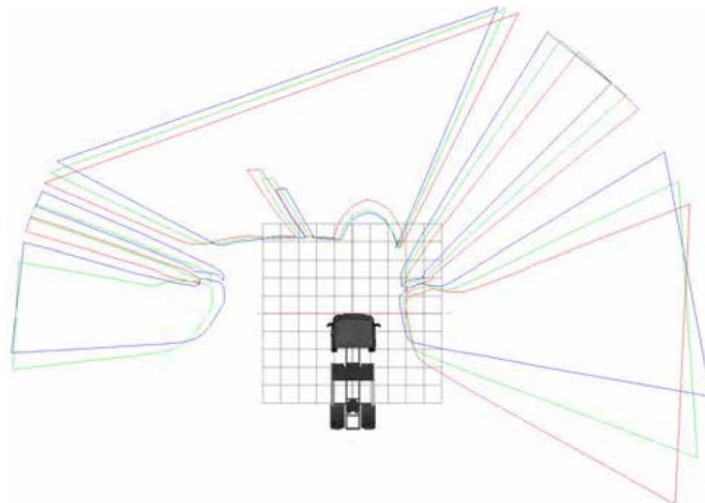


**Figure B.2. Spherical projection of driver's FOV through windscreen and nearside window (Summerskill, Marshall, Paterson, & Reed, 2015)**

The reporting of results consists of these quantitative results as well as 3D and 2D diagrams visualising the field of view on the sphere, in planes of different heights (Figure B.3) and for different driver statures (Figure B.4).



**Figure B.3. Exemplary intersection of driver's direct (blue) and indirect FOV (red) with a plane at a height above the ground to represent the height of a 50<sup>th</sup> percentile UK male cyclist (Summerskill, Marshall, Paterson, & Reed, 2015)**



**Figure B.4 Exemplary windscreen and side window projection onto the ground plane for 5<sup>th</sup>, 50<sup>th</sup> and 95<sup>th</sup> percentile driver (Summerskill, Marshall, Paterson, & Reed, 2015)**

### ***B.1.2 Commentary on procedural approach***

The advantages of the methodology are the immediate relevance of the VRU obscuration assessment and the format of reporting that appears very accessible for lay users. The UMTRI driver positioning model appears well-suited for modern HGVs. The detailed modelling takes into account in-vehicle obscuration such as the steering wheel.

The following questions need to be addressed when considering the transposition of the CLOCS/LDS-2015 method into an industry standard:

- The assessment is based on best-selling cab configuration. Should an industry standard take each cab configuration into account individually?
- The criteria for vehicle test configuration and vehicle setup are not prescriptive enough. What needs to be prescribed?
- The study relied on mid-sized driver to compare different vehicles. Is this suitable for a minimum industry standard? How to treat the range of different viewpoints?
- The study relied on mid-sized VRU models (cyclist/pedestrian) to compare different vehicles. Are the statures suitable for a minimum industry standard? Could simpler geometric objects (e.g. narrow cylinders representing top of VRU head height) serve the same purpose or were there cases where the FOV intersected with other body parts than the head? (Note that the reported distance is measured from the outer contour of the VRU, i.e. their arm and not centre of head)
- The VRU obscuration assessment reports the area around the HGV where no fraction of the VRU models can be seen by the driver. Implicitly the user of the results might assume that in the areas not indicated as blindspots, a VRU is 'visible' to the driver. This might however not be the case because a very small fraction of a VRU might not be enough for a driver to see them.

- The results for various HGVs showed that well-performing models based on VRU obscuration assessment can score badly in the FOV spherical area and vice versa. Should the results be reported separately or be weighted and reported combined, in order to not create false incentives? How relevant is the spherical projection in the real world?

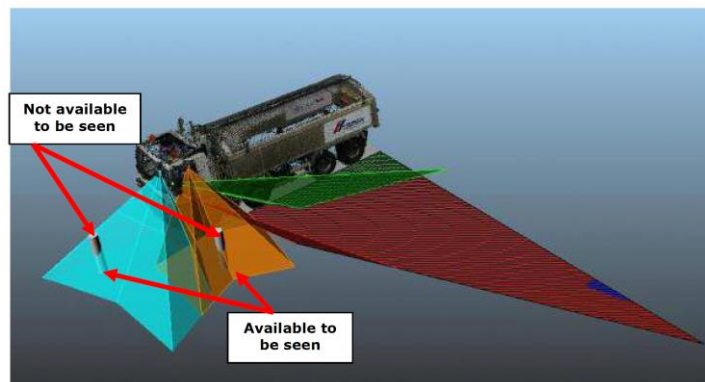
## B.2 CLOCS/TRL-2013

### B.2.1 Summary

As part of TfL’s CLOCS programme, TRL performed an assessment of direct and indirect visibility from three exemplary HGV cabs in 2013. The methodology was not defined specifically to be implemented as an official test procedure but rather to provide a means of comparing the three chosen vehicles. Because of this nature, certain aspects such as seat adjustment and viewpoint positioning are not defined in a reproducible manner.

The procedure is based on positioning a laser assessment tool at the viewpoint of a test driver which projects the visible direct field of view onto the road surface. The projected area on the ground is marked and measured and provides a means for comparing different vehicles.

Additionally, 3D laser scans of the cab are performed and used, in conjunction with the ground markers from the laser projection, for a volumetric projection assessment using CAD. This analyses direct and indirect visibility of objects placed around the vehicle (see Figure B.5). The visual targets used are cylinders, representing pedestrians, and virtual models of cyclists placed at 14 positions along the nearside of the cab.



**Figure B.5. CAD-based visibility assessment for cylindrical object in vicinity of the cab (Delmonte, et al., Construction logistics and cyclist safety: Technical report, 2013)**

### B.2.2 Commentary on procedural approach

The laser projection to determine the ground coverage area of direct vision provides a method of determining a quantitative measure without the need for 3D models. However, an assessment based exclusively on these criteria would not allow a satisfactory assessment.

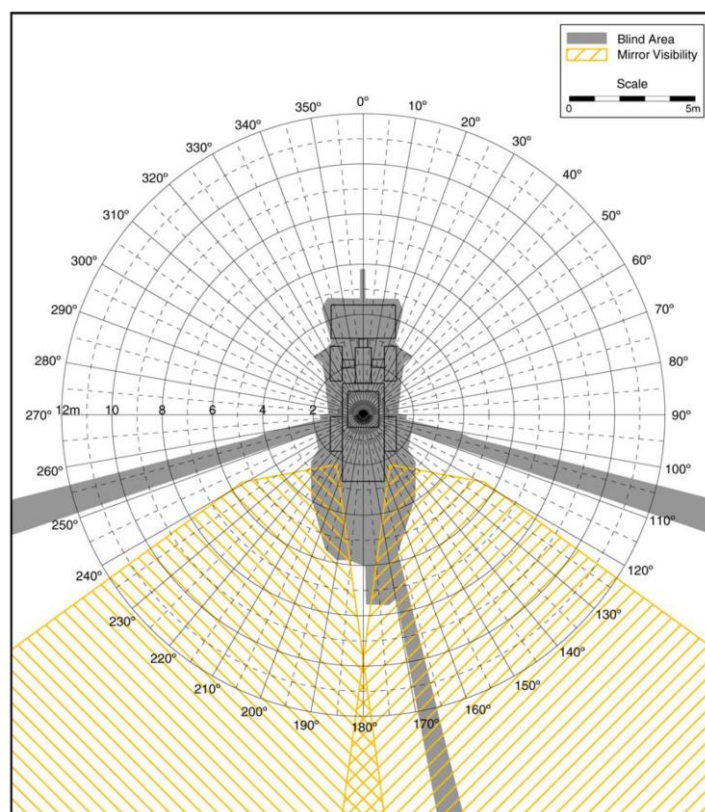
The 3D measurement methods applied laid the ground for parts of the subsequent CLOCS projects and might provide a good base for an official procedure. The measurement method has to be defined in more detail to ensure reproducible and repeatable results. The assessment method does currently not provide a weighting of different zones based on their relative importance.

### B.3 Construction Vehicle Blind Area Diagrams (Caterpillar Inc.)

#### B.3.1 Summary

Caterpillar’s Construction Vehicle Blind Area Diagrams were created by applying the ISO 5006 measurement procedure for direct vision and ISO/CD 14401-1 for indirect vision. Measurements were taken at three different levels: At ground level; 0.9 metres above ground level (height of channelizing devices; relevant mostly for work sites); and 1.5 metres above ground level (slightly below 5<sup>th</sup> percentile female).

The results for the planes are presented in three polar plots, each displaying a top view of the vehicle and the blind areas around the vehicle at a given height (see Figure B.6). No quantitative assessment of the results is performed.



**Figure B.6. Exemplary polar plot visualising the vehicle contour, direct vision blind spots (grey) and indirect vision coverage (yellow hatching) at the given plane above the ground (Caterpillar Inc., 2004)**



### B.3.2 Commentary on procedural approach

The presentation of the results in polar plots is very accessible and easily understandable to the user. However, each of the plots is limited to a 2D view and can therefore not convey some of the complexities surrounding this 3D issue in the real-world.

## B.4 ACEA, Jama, Kama Proposal for a consumer visibility test

### B.4.1 Summary

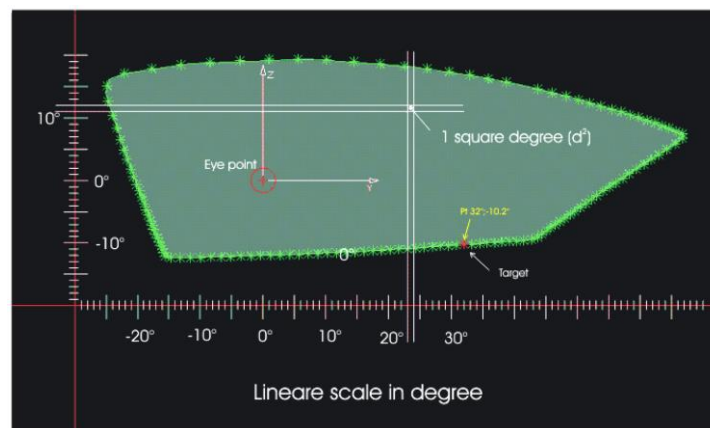
This draft proposal for a Euro NCAP Visibility Protocol was proposed by the automotive industry (ACEA, JAMA, KAMA) in 2004 as part of the Euro NCAP subgroup ‘Visibility and Lighting’. Euro NCAP did ultimately not introduce a visibility assessment. The draft protocol involves creating a CAD model and performing a digital analysis.

The relevance of the protocol is somewhat limited by its draft status which means that not all provisions are fully detailed. For seat adjustment two options are discussed: R-point positioning or mid-range of adjustability. The seat back angle is set to 25 degrees.

The protocol defines specific measurement points for passenger cars to limit the effort of performing a 3D measurement. The relevance of these points is limited because they are specific to cars and modern OEM CAD models will already contain all relevant surfaces.

Direct vision is modelled using ambinocular viewpoints. Driver viewpoints are defined as “V1 and V2 used in normative documents relative to vision, are defined according to the standard procedures”.

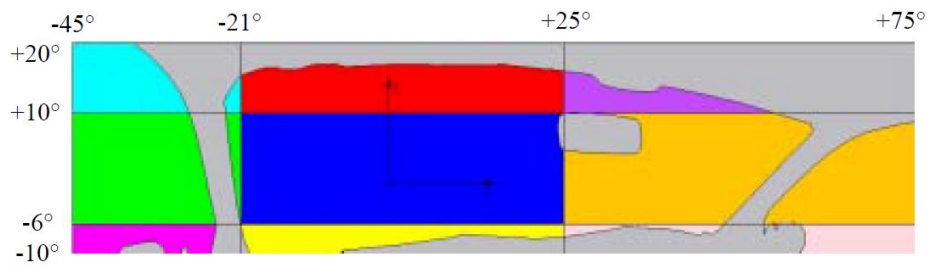
For the assessment of the field of view, the draft protocol offers two alternative methods: Projection onto a sphere or ‘square degrees method’ (Figure B.7).



**Figure B.7. ‘Square degrees’ assessment of direct field of view (ACEA, JAMA, KAMA, 2004)**

Both methods can be used to assess the projected visible area in multiple zones (Figure B.8). These zones are weighted according to their relevance to produce the final score.





**Figure B.8. ACEA/JAMA/KAMA proposal for zones for forward FOV (ACEA, JAMA, KAMA, 2004)**

**B.4.2 Commentary on procedural approach**

The draft protocol was designed for cars and some of the prescriptions, such as definition of measurement points for 3D scanning, are not applicable to HGVs.

The alternative assessment method based on square degrees, rather than projection onto a sphere, is unique to this document.

**B.5 Federal Motor Vehicle Safety Standards (FMVSS)**

**B.5.1 Summary**

Federal Motor Vehicle Safety Standards (FMVSS) are US federal regulations that specify the design, construction, performance and durability requirements of motor vehicles and regulated safety-related components, systems and design features. The forward field of vision of the drivers of cars, MPVs, trucks and buses are regulated in the US by FMVSS 104 “Windshield wiping and washing systems”, with the indirect vision of US car, MPV, truck, bus and school bus drivers regulated by FMVSS 111 “Rearview mirrors”.

The methods employed by FMVSS 104 to regulate the forward field of vision of the driver define the minimum windshield swept area requirements. This requires the windshield wiping system to sweep at least 80% of a rectangular windshield area, specific to the weight of the vehicle being assessed, bounded by planes angled at a tangent to the eye position ellipsoids (Figure B.9). Whilst, unfortunately, not defining the direct field of view of the driver in relation to the exterior of the vehicle, FMVSS 104 does define the seat adjustments, viewpoint positions and viewpoint types used to regulate the forward field of vision for vehicles in the US.

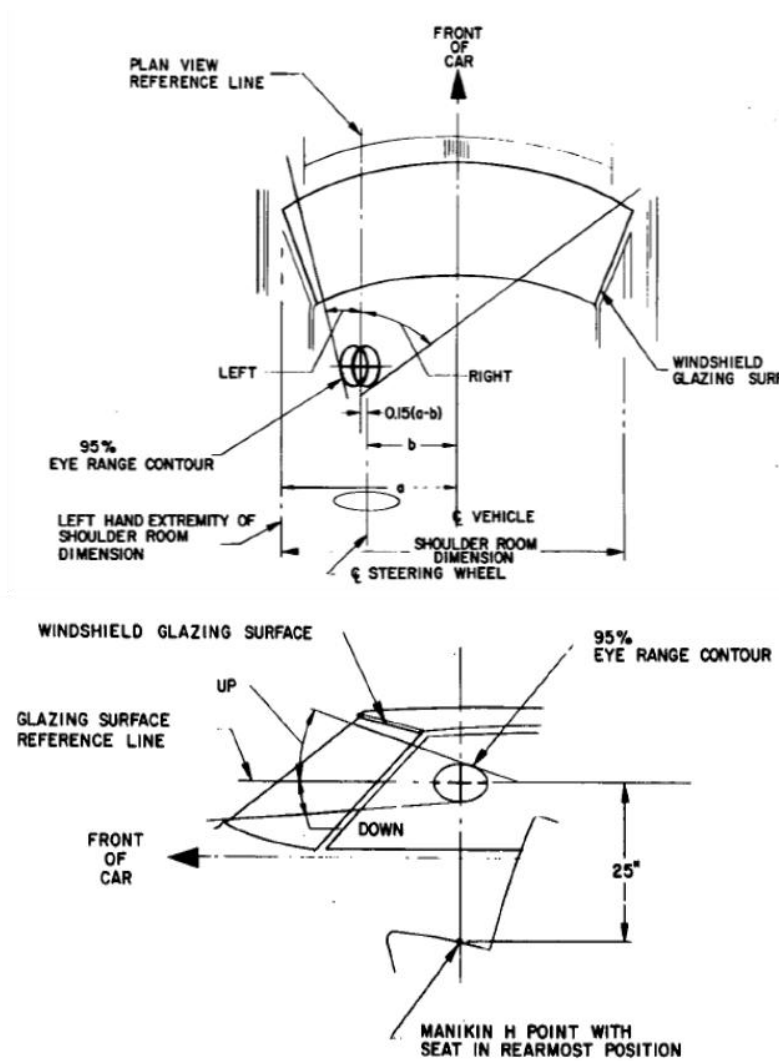
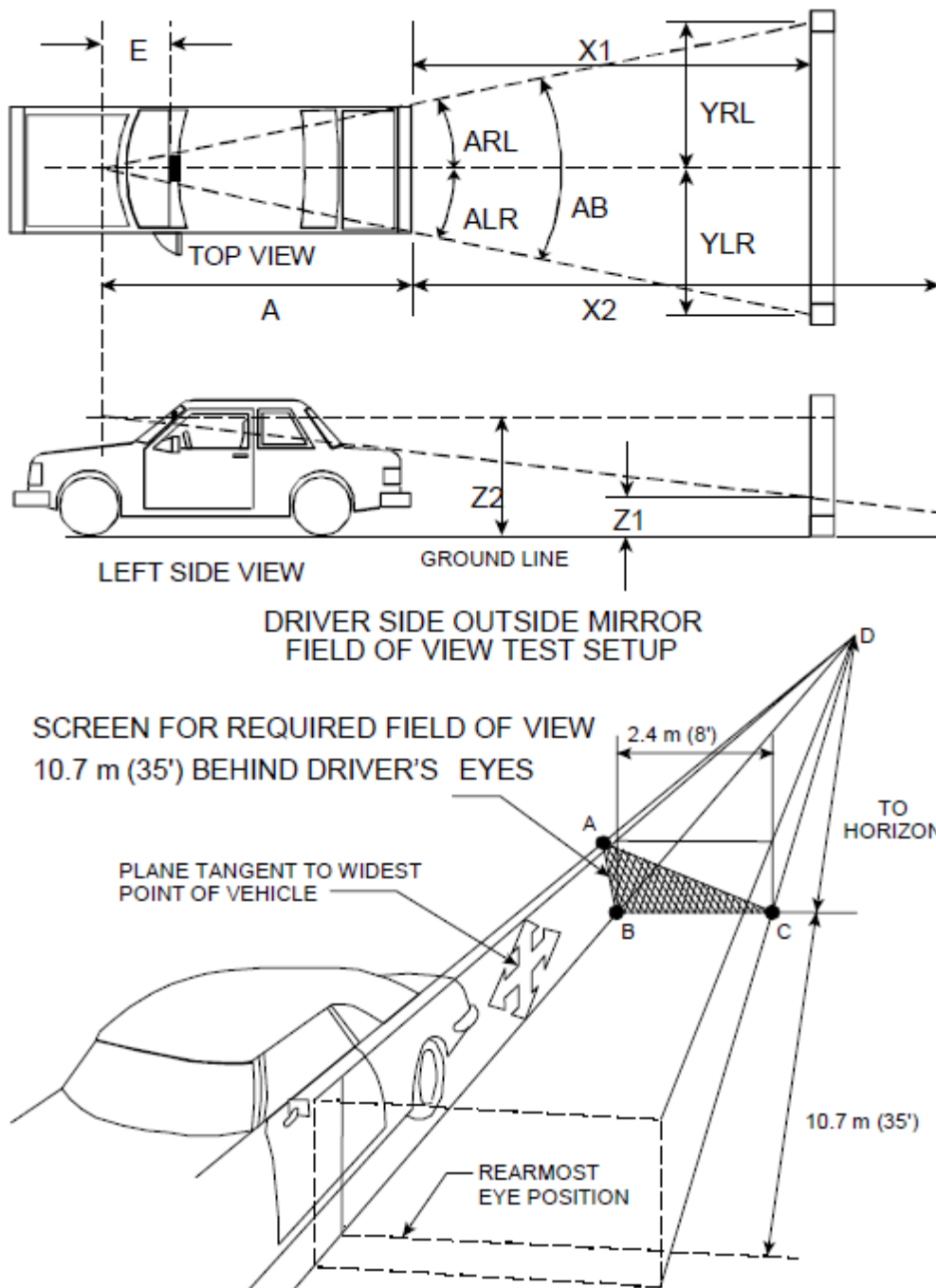


Figure B.9. Plan (top) and side (bottom) view of location of 80% windscreen swept area required by FMVSS 104 (FMVSS 104, 2014)

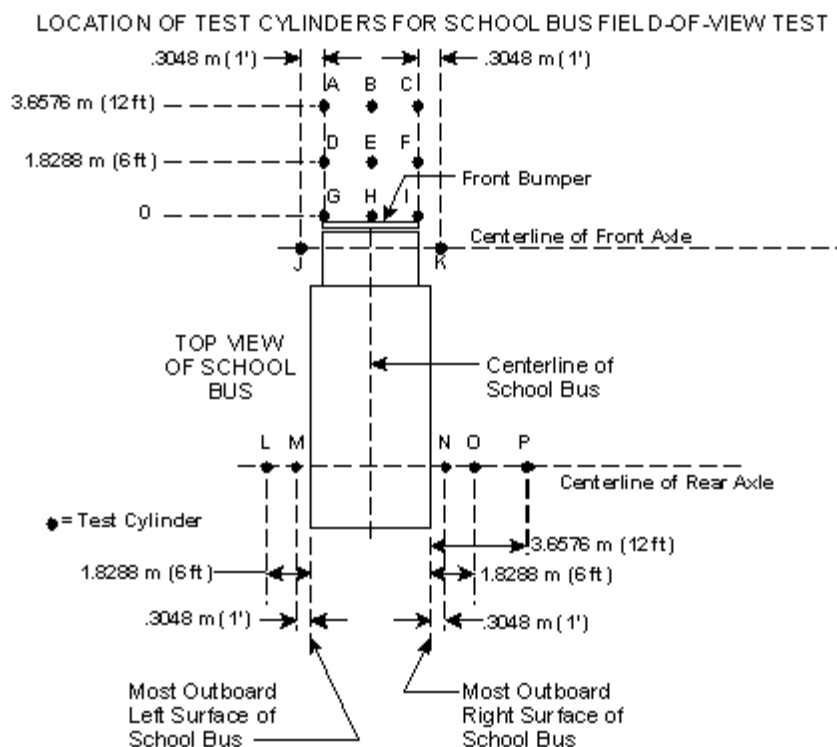


**Figure B.10. Current FMVSS 111 indirect vision regulatory requirements for inner (top) and outside driver side (bottom) mirrors (OVSC, 1999)**

FMVSS 111 regulates indirect driver vision through the implementation of two separate assessment procedures, one which is used for evaluating school buses and one which is used for cars, MPVs, trucks and buses. The assessment procedure for cars, MPVs, trucks and buses describes the marking of the rearward field-of-view extremities for the vehicle mirrors on a test screen located 10.7 m behind the rear-most aspect of the driver eye position ellipsoids. Regulated mirrors include the inside rearview mirror, outside rearview mirrors (driver and passenger sides) and the convex mirror, whilst recommendations for vehicle

preparation, seat adjustment and viewpoint position are also provided. Current standards require the inside mirror to allow a driver to be able to see the ground, across a minimum arc of 20°, at a point of 61 m or less behind the vehicle (Figure B.10), whilst the outside driver-side mirrors are required to provide a driver with a view of an area on the test screen extending 2.4 m out from a plane tangent to the widest vehicle point.

FMVSS 111 standards for school buses, however, provide more specific regulation of the external area surrounding a school bus. The procedures adopted by this aspect of the standard require school buses to have two rearview mirror systems. System A requires mirrors to be located on the left and right of a school bus to enable a specified rearward field of view requirement, whilst System B requires mirrors to enable the area directly in front of the school bus to be viewed, in addition augmenting System A mirrors to enable the front sides of the school bus and further back to be viewed. To determine compliance with FMVSS 111, these standards recommend a camera to be located within a 15.24 cm radius semi-circular area measured from, and forward of, the centre point of the eye location for a 25<sup>th</sup> percentile female driver, whilst also defining requirements for vehicle preparation, seat adjustments and viewpoint positions. This camera should be able to either directly or indirectly (through System A or System B mirrors) view the entire top surfaces of 16 test cylinders positioned at the locations described in Figure B.11 below (A-O: 0.3048 m height, 0.3048 m diameter; P: 0.9144 m height, 0.3048 m diameter) and two markers placed on the ground 61 m rearward of test cylinders M and N.



**Figure B.11. Test cylinder location for the school bus field of view test (OVSC, 1999)**

---

### ***B.5.2 Commentary on procedural approach***

FMVSS 104 and 111 regulate the direct and indirect fields of vision of HGV drivers in the US, with FMVSS 104 regulating minimum HGV windshield swept area and FMVSS 111 regulating the indirect field of vision requirements for internal and external HGV mirrors. Despite providing standardised procedures for vehicle preparation, seat adjustments and viewpoint positions, the methods defined within these standards are only appropriate for determining compliance with the minimum performance requirements for the direct and indirect vision of HGV drivers in the US. Consequently, neither procedure is appropriate for evaluating the relative differences in the direct vision performance of HGVs.

The target object evaluation method used by FMVSS 111 to regulate the field of view for school bus drivers, however, may be better suited to determining differences in the real-world performance of the direct and indirect fields of vision for HGV drivers. By locating 16 test cylinders at strategic locations in the area surrounding a school bus, FMVSS 111 requires school bus drivers to be able to either directly or indirectly view 0.3048 m high cylinders at distances of at least 0.3048 m away from the side of the school bus. This can be extended for evaluating the direct vision performance of HGVs by determining the proportion of cylinders directly visible to the driver. This method could, however, be improved, as no information was provided regarding any evidence base underpinning the rationale for positioning the cylinders and the relative risk weighting of cylinders (which is, in this case, is simply a factor of 1 for all cylinders). Such improvements would be required prior to any further extension of this technique.

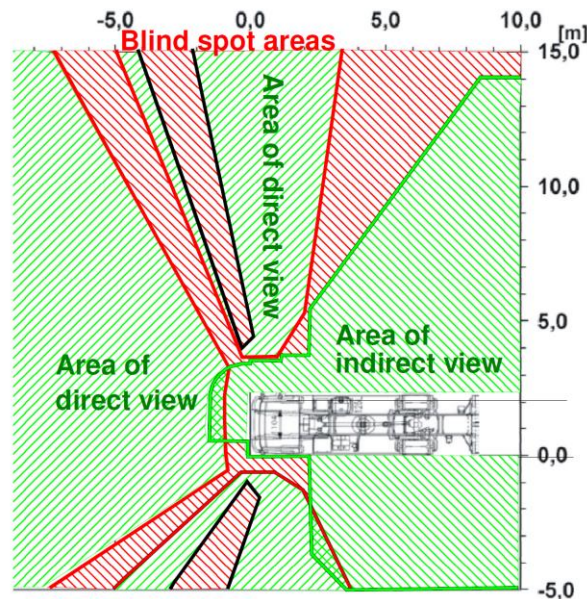
## **B.6 Heavy Vehicle Aggressivity Index (HVAI)**

### ***B.6.1 Summary***

The Heavy Vehicle Aggressivity Index (HVAI) is an assessment procedure for the active, structural and run-over aggressivity of HGVs of cab-over-engine configuration. It was developed in 2008 as part of the research project APROSYS. The index has not been implemented in legislation or in consumer testing yet.

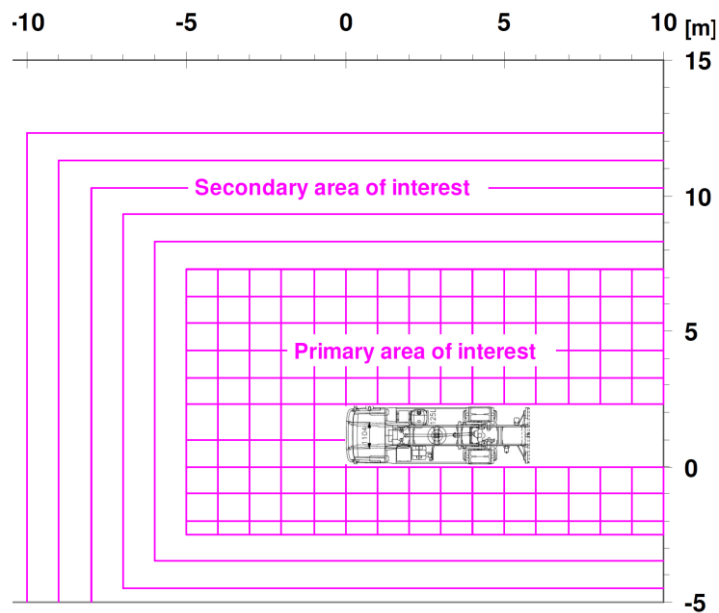
The active part of the index provides a method for a combined assessment of direct and indirect vision from HGV cabs. It was originally performed with technical drawings, but can also be performed with CAD models from 3D scans or manufacturer's models.

The FOV assessment is based on intersections of window and mirror projections with a plane located 1.6 metres above the ground (see Figure B.12). The height was chosen to represent the centre of head of a standing 50<sup>th</sup> percentile male.



**Figure B.12. Exemplary HVAI diagram of direct and indirect vision at 1.6 metres above ground level (Smith, et al., 2008)**

For the assessment, two different areas of interest around the vehicle are defined; one in close, one in wider distance of the vehicle (see Figure B.13). The assessment is based on the proportion of these areas being visible in direct and/or indirect vision.



**Figure B.13. HVAI definition of primary and secondary areas of interest (Smith, et al., 2008)**

To calculate a single result, weighting factors are applied for primary vs. secondary area and visibility in direct vs. indirect vision. Overlap of direct and indirect vision is desired and rewarded by a modifier.

A combined rating between 0 and 10 is reported as a single result for a vehicle.

---

### ***B.6.2 Commentary on procedural approach***

The method of performing a visual intersection at a given height is largely equivalent to the assessment of visibility of a simple geometric object of that size (not identical if there are obscurations present entering the FOV from above). However, the height of the plane can change the relative outcome of different cab designs (e.g. design 1 appearing better in a rating for children, design 2 appearing better in a rating for adults). It is therefore paramount not to create false incentives by choosing an unsuitable height. Assessments at more than one height could be combined.

The method of applying weighting factors based on the relative importance of different zones appears well-suited for an assessment with real-world relevance. The zone dimensions, weighting factors and modifiers are based on expert judgement and experience from accident research. Additional objective quantitative analysis of real-world accident data could further support the validity of weighting factors and modifiers.

The results are reported in one combined score. If this combined score correlates well with the real-world safety performance of the rated vehicle, this simplicity is a major advantage in making the results accessible for lay users and for including them in commercial contracts.

## **B.7 HGV VRU test protocol**

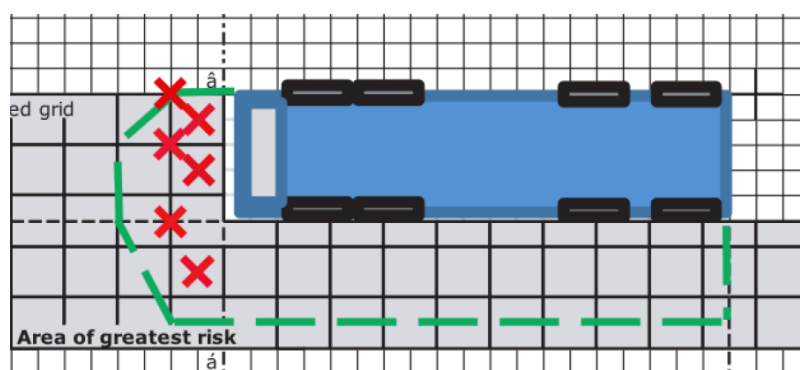
### ***B.7.1 Summary***

The HGV VRU test protocol, developed in 2015 by TRL for TfL, provides an assessment protocol for devices that give HGV drivers warnings of VRUs. It is as such not designed to assess the direct or indirect vision from a vehicle but was included in this review because some assessment methods and zones could be relevant.

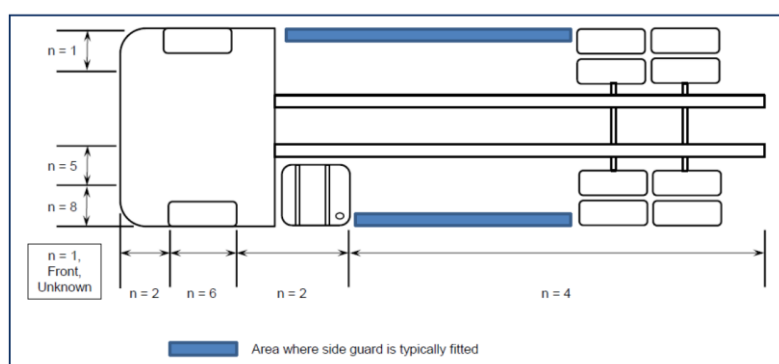
The test protocol defines a series of tests with VRU dummies (pedestrians and cyclists) in relevant scenarios in vicinity of the sensor-equipped vehicle (see Figure B.14 and Figure B.15). The assessment is based on a whether the system provides a warning. The test scenarios are:

- Moving off test for pedestrian VRU
- HGV turns left & cyclist goes straight ahead (overtaking)
- HGV turns left & cyclist goes straight ahead (undertaking)
- HGV and cyclist both turn left at a junction
- Cyclist with HGV following
- HGV going straight ahead with pedestrian crossing in front





**Figure B.14. Six test positions for pedestrian dummy in ‘moving off’ test (Torkington, Robbins, Jenkins, & McCarthy, 2015)**



**Figure B.15. Relevant areas for cyclist collisions; indicating first contact point between HGV and pedal cyclist from Stats19 analysis (Torkington, Robbins, Jenkins, & McCarthy, 2015)**

The vehicle under test and the dummy are stationary for some of the above and, for others, moving at varying speeds (HGV driving; dummy moving on a rail). The dummies prescribed for the different scenarios were selected to represent the most frequent casualty in each scenario; e.g. a male pedestrian dummy for the moving vehicle tests.

The warning signal must be provided early enough for the driver to stop before hitting the VRU, in order to successfully complete a scenario. The tests are complemented by a human factors assessment of the audible/visual or tactile signal, the location and layout of the system and the mental demands.

The final assessment of system is presented as a star rating, reaching from zero to four stars. The rating is derived from the scores of the individual tests described above. The positive activation tests make up approximately 53% of the test score; the false activation tests 29%, and the human factors assessment 18%.

**B.7.2 Commentary on procedural approach**

The definition of the area of greatest risk and the scenarios are relevant and should be taken into account when defining a direct vision assessment protocol. Other aspects of the procedure are of limited relevance for a FOV assessment.



---

## B.8 ISO Standards

### B.8.1 Summary

Current active International Organization for Standardization (ISO) standards that define procedures for assessing the direct and indirect vision of vehicle drivers include ISO 4513, ISO 5006, ISO 7397-1, ISO 7397-2, ISO 14401-1 and ISO 14401-2. ISO 4513 describes a method for defining the eye point ellipses (or eyellipses), that statistically represent driver eye locations, which can be used to enable the design and evaluation of direct and indirect vision in all motor vehicles. ISO 5006 describes the methods and performance criteria used for assessing the direct and indirect fields of view of operators using earth-moving machinery. ISO 7397-1 and ISO 7397-2 (hereon referred to as ISO 7397) can be used in combination to verify that the forward field of view of a passenger car driver achieves the requirements of EEC Directives 77/649 and 88/366 (now UNECE Regulation 125). Finally, ISO 14401-1 and 14401-2 (hereon referred to as ISO 14401) can also be used in combination to test and assess the indirect field of vision of operators using the surveillance and rear-view mirrors on earth-moving machinery.

ISO 4513 establishes eye point locations for the driver of a vehicle. Statistically derived elliptical models (eyellipses) in three dimensions are used to represent cut-off percentiles for the driver eye point locations. Procedures are provided by this standard to construct adjustable and fixed seat tangent cut-off eyellipses for adult drivers with any gender and stature mix and for any desired tangent cut-off contour. Neck pivot points are further defined by this standard to establish the location of left and right eye points that are used to assess the field of view for specific direct and indirect vision tasks.

ISO 5006 provides the testing procedures and performance requirements to assess both the direct and indirect field of view for the operators of earth-moving machinery. The test procedure described by this standard uses two lights, positioned within an area that defines the range of potential operator eye locations, to assess the minimum boundary masked by the machine, its components and attachments. This masking is determined at the ground plane for the machine both on a boundary line 1 m away from the smallest rectangle encompassing the machine and on a 12 m radius visibility test circle centred on the midpoint of the two light bulb filaments (Figure B.17). To establish the visibility performance criteria of the machine a combination of eye spacing and masking widths are used for each particular machine design, with these criteria based on the physical characteristics of human operators and ground personnel. Where operator direct vision is considered inadequate, it is considered acceptable to use additional devices for indirect visibility (mirrors or closed-circuit television cameras) to achieve acceptable visibility.

ISO 7397 specifies the test methods for verifying the compliance of a passenger car with the requirements of EEC Directives 77/649 and 88/366 for the 180° forward field of view of the driver. UNECE Regulation 125, which was drafted based on ISO 7397, has since succeeded these ISO standards, with further evaluation of the methods and assessment criteria implemented by UNECE Regulation 125 provided in Section B.13.

---

Finally, ISO 14401 specifies the testing procedures and performance assessment criteria for evaluating the field of vision of operators using surveillance and rear-view mirrors on earth-moving machinery. Importantly, the test procedures adopted by this standard are aligned with ISO 5006, to allow mirrors to fulfil the requirements for both ISO standards. The test procedure described by ISO 14401 therefore uses two lights, positioned within an area that defines the range of potential operator eye locations (as in ISO 5006), to assess the visibility of the lights in the mirrors of the machine at measurement locations specific to the vehicle assessed. To comply with these standards, each vehicle must have an indirect field of view that allows the visibility of the lights in a mirror within a defined area that extends at least 30 m rearward from the eye point of the operator.

### ***B.8.2 Commentary on procedural approach***

Current ISO standards define several aspects of the testing procedures and a number of potential performance criteria relating to the assessment of the direct and indirect fields of view for vehicle drivers, in particular for operators of earth-moving machinery. All four ISO standards identified in this review propose a range of test methods and performance criteria for assessing the direct and indirect fields of view for vehicle drivers, which have several advantages and disadvantages for the development of future HGV direct vision testing protocols.

ISO 7397 specifies similar testing and assessment procedures to UNECE Regulation 125, with these critically appraised in greater detail in Section B.13. ISO 4513, on the other hand, establishes the standards for determining adjustable and fixed seat tangent cut-off eyellipses for drivers with any gender and stature mix and for any desired tangent cut-off contour, but does not expand any further on either test procedures or performance assessment criteria. This standard would perhaps therefore be very interesting for the development of future standards that seek to use the eyellipse tangent cut-off contour, as this gives the generalised equations that would allow the calculation of the critical size and location dimensions for the eyellipses.

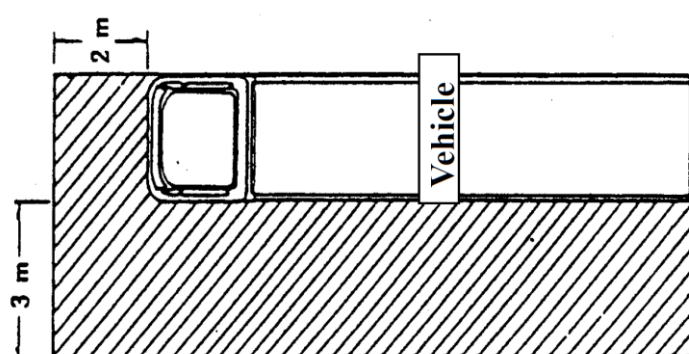
Although ISO 5006 and ISO 14401 have aligned testing procedures, with both standards assessing the visibility of two lights at specified locations, fundamental differences exist in how these procedures are deployed. Although these standards would be best used in combination, ISO 5006 defines the more robust assessment procedure as it requires the evaluation of the direct and indirect masking of the test lights at boundary lines located 360° around the vehicle and at distances of 1 m and 12 m away from the vehicle. Whilst the assessment criteria used by ISO 5006 does lend itself to assessing the relative direct vision performance vehicles (as vehicles may mask different proportions of the boundary line), such a technique will not be easily related to any specific evidence-base associated with accident risk. ISO 14401 seems even less appropriate for assessing performance, as this requires only a binary response in regards to whether the test lights were visible in the mirrors at specific test locations. The use of test lights positioned within an area that defines the range of potential operator eye locations could, potentially, be a robust and cost-effective method to determine the direct and indirect visibility performance of HGVs.

## B.9 Japanese Safety Regulations

### B.9.1 Summary

Japanese legislation prescribes mandatory minimum visibility standards for cars and heavy duty trucks of cab-over-engine configuration (< 8 tonnes). The requirements are set out in Japanese Safety Regulations Article 44. They rely on a combined assessment of direct and indirect vision.

The assessment is performed for an area extending 2 metres to the front and 3 metres to the nearside of the vehicle (Figure B.18). Within this area a cylindrical object of 1 metre height (representing a child of 6 years of age) must be at least partially visible to the driver. The result is a binary pass or fail of a vehicle.



**Figure B.16. Vision assessment zone in front and at the nearside (right hand drive vehicle) for Japanese HGV type-approval (GRSG expert from Japan, 2003)**

The assessment of direct and indirect FOV is combined; i.e. there is no difference in result whether the cylinder can be seen in direct or indirect vision or both. Certain vehicle parts that might obscure driver's vision (wipers, steering wheel, A-pillars and outside rear-view mirror) are excluded from assessment, i.e. treated as if they were not existent.

Note that Japan is in the process of amending national legislation to make it compatible with UN Regulation No. 46 (GRSG expert from Japan, 2015).

### B.9.2 Commentary on procedural approach

The visual object representing a child of 6 years is based on the assumption that from this age a child could be expected to cross the road in front of an HGV without an accompanying parent. The assessment methodology appears simple to execute, however the method is not very prescriptive with regard to vehicle preparation and details of the procedure.

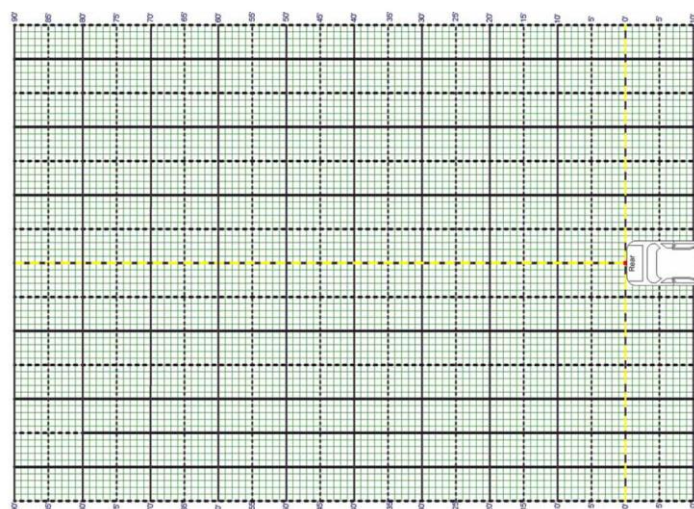
The binary pass/fail approach lends itself to legislation more than to a rating scheme. A multi-level pass/fail approach would be conceivable for a rating system (e.g. a minimum area that has to be directly visible to get a 3-star rating, irrespective of overall score).

## B.10 NHTSA 2008 rear visibility assessment

### B.10.1 Summary

The NHTSA-2008 rear visibility assessment procedure was designed for a research project to determine the range of rear visibility blind zones of light vehicles (i.e. passenger cars, SUVs, pickup trucks) sold in the USA.

The procedure assesses direct and indirect visibility in an area extending 35 feet (ca. 10.7 metres) to either side of the vehicle’s centreline, 90 feet (ca. 27.4 metres) back, and 10 feet (ca. 3.0 metres) forward from the vehicles rear end.



**Figure B.17. NHTSA-2008 rear visibility assessment grid (Mazzae & Garrott, 2008)**

A visual target is moved around the test area to determine the closet sight distance behind the vehicle at which the object is visible. The test area ground is marked with a grid of lines 1 foot apart, forming squares for which visibility is assessed (see Figure B.17).

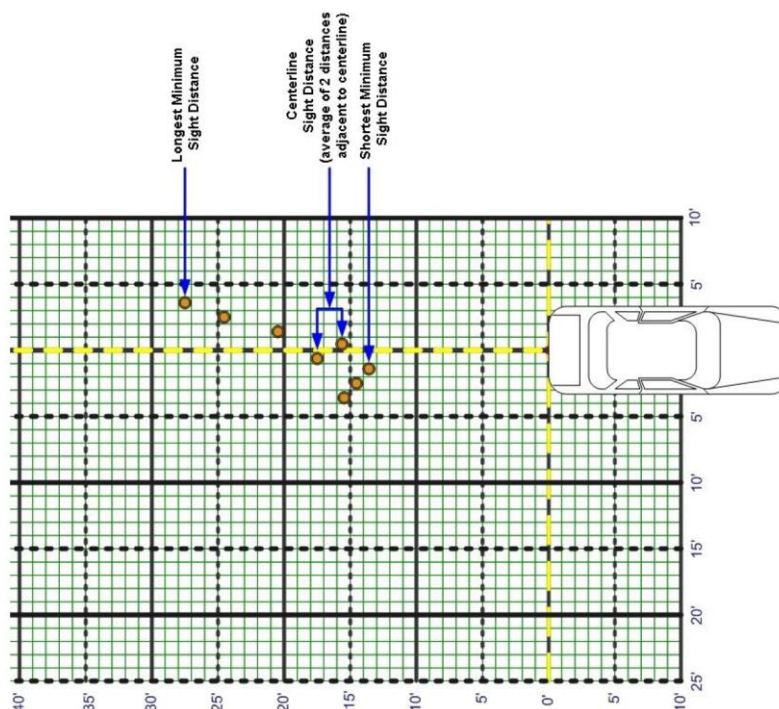
The visual target used is a 29.4 inch / 74.7 centimetre tall traffic cone with a 3 inch / 7.6 cm circular reflector atop. The target is intended to represent a 1 year old child (average between average height of boy and girl). The reflector shall represent the child’s head, although the authors acknowledge that the diameter was somewhat smaller than a child’s head (5 inch / 12.7 centimetres), without further discussing the underlying reasons.

The judgement of whether or not the target is visible is performed by a person sitting in the driver’s seat. The target was considered visible if the entire reflector atop the cone was visible in either direct or indirect vision. The results for each square (visible / not visible) were noted manually in a spreadsheet.

The assessment was performed with a 50<sup>th</sup> percentile male and 5<sup>th</sup> percentile female driver. The seat adjustment is not discussed in detail. The drivers were instructed to rest their weight fully on the seat and rest their feet on the pedals as they would during driving. For the direct field of view assessment the drivers turned their head and moved their torso.

The assessment results for each vehicle were reported as:

- Shortest, longest, centreline and average sight distance from eight positions across the rear of the vehicle (see Figure B.18).
- Direct view rear blind zone area: Size of the zone behind the vehicle in which the target cannot be seen in direct view. Multiple calculations were performed using assessment areas between 90x70 foot wide (ca. 27.4x21.3 metres) and 50x6 foot wide (ca. 15.2x1.8 metres).



**Figure B.18. Exemplary rear sight distance plot (Mazzae & Garrott, 2008)**

### ***B.10.2 Commentary on procedural approach***

The measurement method is very simple to carry out and the test equipment requirements are minimal (visual target, grid on the ground). The reproducibility of results could be increased by defining vehicle and in particular seat adjustment in more detail. The use of human testers can be expected to limit reproducibility and repeatability of the method.

The assessment method based on sight distances and blind area is easily understandable. It is unknown how well the assessment criteria shortest, longest, centreline and average sight distance and blind area correlate with real-world accident data.

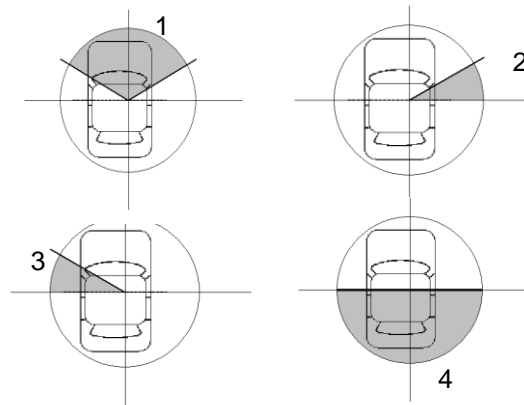
The choice of visibility target is unique. The authors prescribe an object that is roughly representative of the shape of a child’s torso and head (traffic cone and circular reflector atop). In other procedures, simple cylindrical objects are often used. The question of what proportion of a person needs to be visible to allow detection by a driver is decided by the authors by setting the cut-off between visible and non-visible where the entire reflector (i.e. head) can be seen. The authors do not bring forward evidence for this approach but it appears a pragmatic solution.



## B.11 Primary New Car Assessment Programme (PNCAP) Visibility Protocol

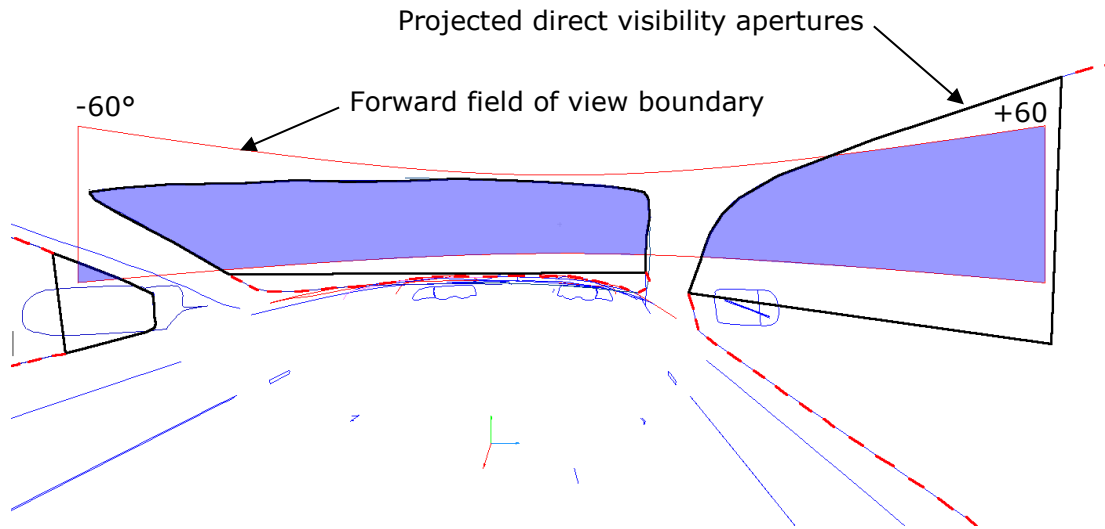
### B.11.1 Summary

The Primary New Car Assessment Programme (PNCAP) protocol describes the testing procedures and assessment criteria used to determine the regions of direct and indirect visibility available to passenger car drivers. The extent of direct visibility is assessed for four zones for a 360° field of view within defined vertical boundaries (Figure B.20).



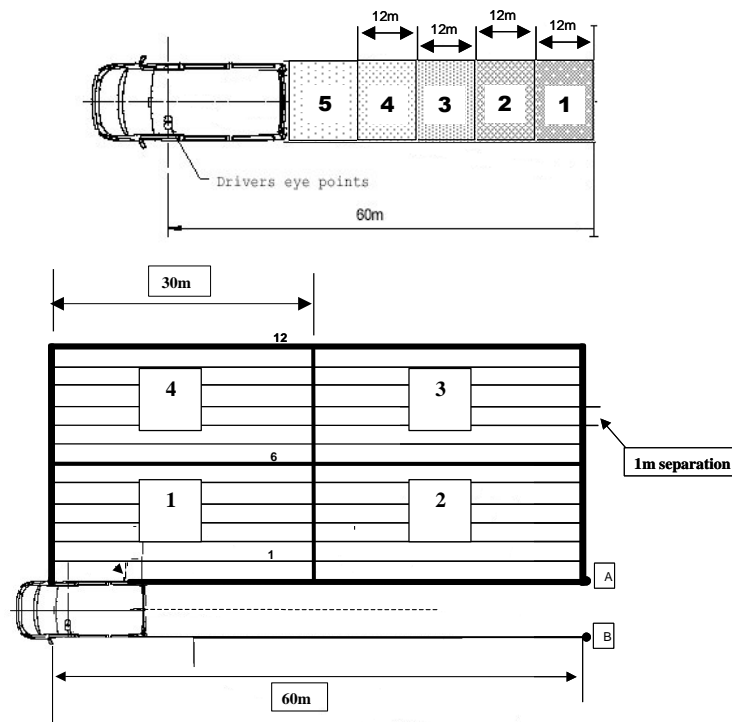
**Figure B.19. Critical zones for assessing the direct visibility performance of a right-hand drive vehicle (TRL, 2003)**

To assess direct visibility, the PNCAP test procedures require the location of the vehicle apertures, vehicle mirrors and driver eye points to be recorded in a 3D reference system using a 3D coordinate measuring device with a maximum sensitivity of  $\pm 2$  mm. A CAD analysis procedure is then used to interpret a 3D model of the relevant vehicle parts, which, using monocular eye points positioned for 5<sup>th</sup> and 95<sup>th</sup> percentile adults, is used to project direct visibility apertures onto a virtual 10 m radius sphere centred at the driver eye point. The projected apertures define areas on the virtual sphere surface which are then bounded by horizontal and vertical fields of view limits relevant to the critical zones for safe driving. The total area of the truncated apertures within each critical zone is then determined for assessing the extent of direct visibility (Figure B.21).



**Figure B.20. Truncated apertures (purple) illustrated for forward field of view (Zone 1) of a right-hand drive vehicle (TRL, 2003)**

To assess indirect visibility, the PNCAP test procedures require the calculation of the area of the ground plane made visible to the vehicle mirrors within three defined assessment zones (Figure B.22). By placing a video camera at the monocular eye points of a 5<sup>th</sup> and 95<sup>th</sup> percentile adult and moving an assessment target along the prescribed lines towards the vehicle, the area of visibility can be calculated for each zone to assess the extent of indirect visibility.



**Figure B.21. Critical zones for assessing indirect visibility performance for the rear-view (top) and driver side-view (bottom) mirrors of a left-hand drive vehicle (TRL, 2003)**



To calculate a single overall PNCAP visibility rating score, weighting factors are applied to the assessed zones based upon how critical they are for performing common driving tasks, before also weighting based on the relative importance of direct vs. indirect vision for detecting hazards. When combined with a rating score related to the defrosting and demisting of the windscreen, windows and mirrors, a combined PNCAP visibility rating score between 0 and 5 is reported as a single result for the vehicle.

### ***B.11.2 Commentary on procedural approach***

The PNCAP protocol provides a robust driver visibility assessment method as it requires the combined evaluation of the direct and indirect fields of view of the driver. The use of a bounded spherical area to define the critical direct visibility zone for a vehicle provides a relevant technique for determining VRU obscuration. Unfortunately, the boundary lines used in PNCAP have been created for passenger car drivers and these would require an update before applying to HGVs. Similarly, the assessment methods used to determine the extent of indirect visibility will need to be extended to include the extra mirrors that may be attached to, and fields of view that may be associated with, HGVs. The detailed modelling proposed by these procedures also takes into account in-vehicle obstructions, such as the steering wheel, which further improves the validity of the process.

The method of applying weighting factors based on the relative importance of different zones appears well-suited for an assessment with real-world relevance. The zone dimensions, weighting factors and modifiers are based on expert judgement and experience from accident research. Additional objective quantitative analysis of real-world accident data could further support the validity of weighting factors and modifiers.

The results are reported in one combined score. If this combined score correlates well with the real-world safety performance of the rated vehicle, this simplicity is a major advantage in making the results accessible for lay users and including them in commercial contracts.

## **B.12 SAE Standards**

### ***B.12.1 Summary***

Current active Society of Automotive Engineers (SAE) standards that define procedures for assessing the direct and indirect vision of vehicle drivers include SAE J903a, SAE J941, SAE J1050 and SAE J1750. SAE J903a can be used to verify that the forward field of view permitted by a passenger car achieves the minimum windshield wiper swept area requirements as currently described by FMVSS 104. SAE J941 describes a method for establishing the eyellipses, which statistically represent driver eye point locations, and that can be used to enable the design and evaluation of direct and indirect vision in all motor vehicles. SAE J1050 further supplements SAE J941 by establishing three methods that can be used to describe and measure the direct and indirect fields of view of the driver. Finally, SAE J1750 provides three methods, including a Target Evaluation Method, for describing and evaluating the direct and indirect fields of view for HGV drivers.

---

SAE J903a specifies the test methods for verifying the compliance of passenger cars with the requirements for the minimum swept area of the windshield. FMVSS 104, which was drafted based on SAE J903a, has since succeeded these SAE standards, with the further evaluation of the test methods and assessment criteria required by FMVSS 104 provided in Section B.5.

SAE J941 is aligned with ISO 4513 to establish the eye point locations for vehicle drivers. Procedures are defined by both standards to construct adjustable and fixed seat tangent cut-off eyellipses and eye points for adult drivers with any gender and stature mix, and for any desired cut-off contour, to assess the field of view for specific direct and indirect vision tasks. Again, further evaluation of these procedures is provided in Section B.8.

SAE J1050 describes three methods for measuring the direct and indirect fields of view of the driver and the extent of the obstructions to those fields of view. The first method uses any single pair of eye points to determine the fields of view and obstructions to the fields of view that would be seen by an individual driver. The second method uses the eyellipses defined in SAE J941 to determine the largest fields of view or obstructions that would be seen for a given percentage of the driving population. The third method uses specific eye points defined in SAE J941 to measure the extent of a direct or indirect field of view or obstruction for the specific driving task that the eye points were developed (rear-view mirror, steering wheel, A-pillar obstructions etc.). This standard provides the procedures for establishing the monocular, binocular and ambinoocular fields of view and obstruction angles for each of these methods.

SAE 1750 establishes three alternate methods for describing and evaluating the viewing environment of the truck (Class B, 6, 7 and 8 vehicles) driver; the Target Evaluation, the Polar Plot and the Horizontal Planar Projection methods. The Target Evaluation method describes the field of view of the driver as a volume around the vehicle to demonstrate areas that may be visible and obstructed to the view of the driver. The Target Evaluation Method is intended to represent positions of cylindrical objects around a vehicle, typically located on the ground plane, and constructed from three stacked sections (coded red, yellow and green) each 0.4 m in diameter and height. The coordinates for each cylinder position are defined in relation to a given vehicle, with each cylinder point located on a 0.485 m x 0.485 m grid pattern that has two points of origin at the central front and rear extremities of the vehicle. This grid is then split into 12 zones around the vehicle, with the dimensions for each zone based on a standard US road lane width, with the direct and indirect fields of view of the driver projected from a monocular viewpoint onto the cylinders. These procedures may be conducted through the use of either a 3D CAD modelling process or manually, with an appropriate physical layout, in lieu of CAD modelling capabilities.

The Polar Plot method presents the field of view available to the driver using a spherical coordinate system centred on the driver eye point location, whereas the Horizontal Planar Projection method projects the field of view of the driver onto a plane positioned at a given elevation. Procedures for calculating both the direct and indirect fields of view of the driver are presented for all three methods defined within this standard, with these procedures defined for monocular driver viewpoints only. Viewpoint locations and types are defined based on SAE J941.

---

### ***B.12.2 Commentary on procedural approach***

Individually, these SAE standards provide several testing and assessment procedures for defining the extent of the direct and indirect fields of view of the driver, but fail to relate these to relative evidence-based assessment criteria. When taken in combination, these standards can be used to define and select the most appropriate viewpoint location, viewpoint type and assessment procedure for the desired analysis. It would be left to the investigator, however, to determine evidence-based assessment criteria for the selected approach.

Whilst the majority of these standards are aligned with other standards (particularly SAE J903a and SAE J941), the Target Evaluation method described SAE 1750 is perhaps one of the more robust procedures for determining the extent of the direct and indirect fields of view for HGV drivers. The Target Evaluation assessment procedure proposed by SAE 1750 determines the obscuration of standardised objects at discreet locations within specific zones, which can be used to rate the relative visibility performance of HGVs. This could allow the calculation and comparison of the relative volume of space visible to the driver of a HGV and can be performed within both the 3D CAD modelling and physical laboratory environments. Again, evidence-based criteria would need to be developed to weight the relative importance of the zones and cylinder heights against their associated VRU incident risks.

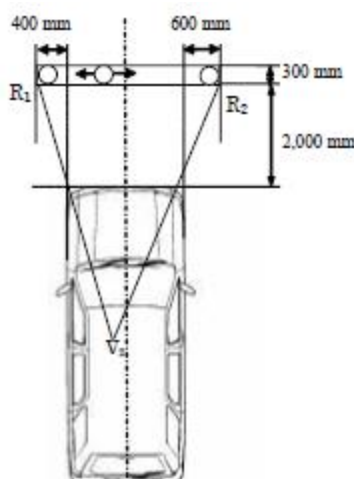
## **B.13 UN Regulations**

### ***B.13.1 Summary [46 and 125]***

United Nations (UN) Regulations for automobiles are international regulations concerning lighting, controls, crashworthiness, environment protection and theft protection. The forward field of vision for the drivers of category M<sub>1</sub> vehicles (i.e. cars) are regulated in the EU by UN Regulation 125, with the indirect vision of EU cars regulated by UN Regulation 46. Although both standards similarly regulate the preparation of the vehicle prior to testing, the driver eye point locations and driver eye point type (monocular, binocular and ambinoocular viewpoints all used for specific test procedures), several differences exist between the two testing and assessment procedures exist.

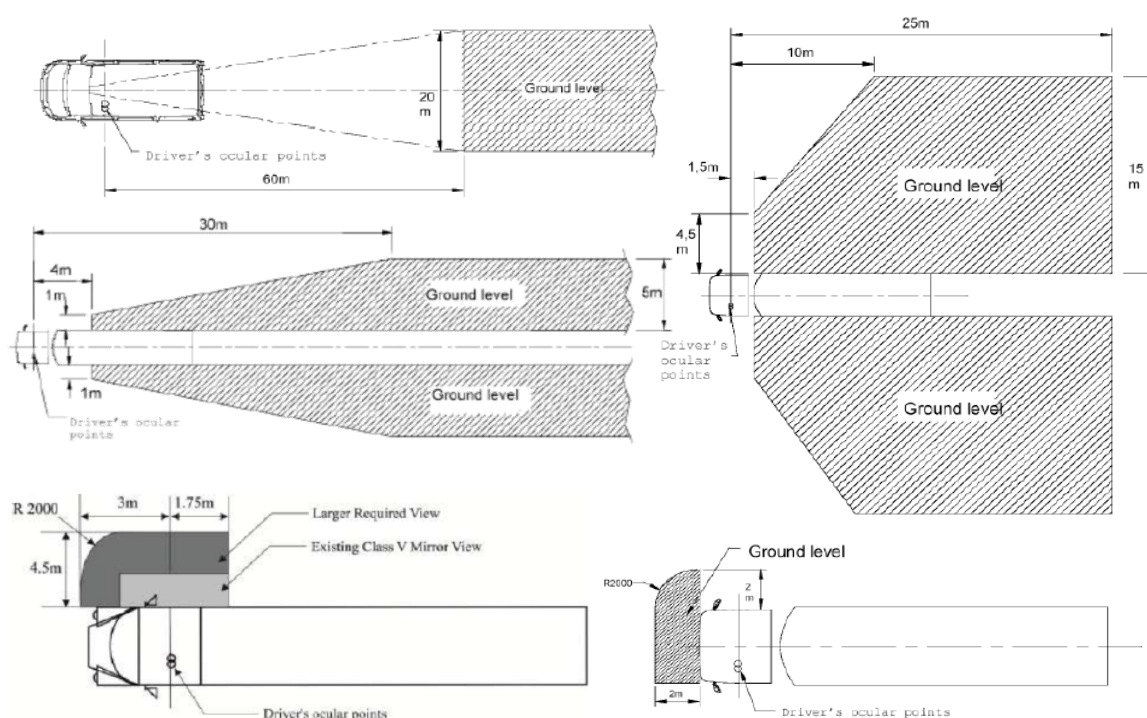
To regulate the forward field of vision of a vehicle driver, UN Regulation 125 defines four specific requirements. The first is definition of the minimum transparent area of the windscreen, requiring this to be completely transparent and with at least 80% of this area swept by the windshield wiper system, whilst the second is a definition of the minimum A-pillar obstruction angle. The third is the requirement that, aside from specified exceptions (i.e. A-pillars, printed radio aerials, windscreen wipers, rear-view mirrors etc.), there are no obstructions to the 180° forward field of view of the driver within specified boundary planes. Finally, in cases where the viewpoint of a 5<sup>th</sup> percentile driver in the vehicle is higher than 1,650 mm, a target object evaluation method requires the driver to at least partially view a cylindrical target within a specified area in front of the vehicle.

Of these requirements, it is perhaps only the final procedure which may be translated to establish the relative direct vision performances available to HGV drivers. This procedure uses a 1,200 mm tall and 300 mm diameter cylinder positioned within a space bounded by vertical planes located at 2,000 mm and 2,300 mm in front of the vehicle, 400 mm outboard from the driver side of the vehicle and 600 mm outboard from the passenger side of the vehicle. This cylinder should be at least partially visible when viewed directly from the viewpoint of a 5<sup>th</sup> percentile driver, regardless of where the object is within that space (Figure B.25), with the exception of obstructions caused by A-pillars, windscreen wipers or steering wheels.



**Figure B.22. Target evaluation method (UN Regulation 125, 2013)**

UN Regulation 46 regulates indirect driver vision by applying a single test procedure to establish whether all six compulsory and optional HGV (N<sub>3</sub>) mirror classes allow the driver to view a specific minimum field of vision requirement. The technique recommended by UNECE 46 to determine the field of vision of each mirror at the ground plane is to place powerful light sources at the eye points of the driver to examine the light reflected onto a vertical monitoring screen (although other equivalent methods may be used), therefore, using ambinoocular vision to assess the indirect field of vision. As HGVs require four compulsory mirrors (Classes II, IV, V (on passenger's side) and VI) and are also allowed a further two optional mirrors (Classes I and V (on driver's side)), up to eight fields of view are currently regulated by UN Regulation 46 for HGVs (Figure B.23). Unfortunately, no comparative assessment of indirect vision performance between HGVs can be made for UN Regulation 46, as these regulations provide the minimum requirements for these fields of view only.



**Figure B.23. HGV specific indirect fields of view requirements (UN Regulation 46, 2014)**

**B.13.2 Commentary on procedural approach**

UNECE 125 and 64 regulate the direct and indirect fields of vision of HGV drivers in the EU, with UNECE 125 regulating the forward field of vision of a vehicle driver through four separate assessment methods and UNECE 64 regulating the indirect field of vision of internal and external HGV mirrors. Despite providing standardised procedures for vehicle preparation, seat adjustments and viewpoint positions, the methods defined within these regulations are similar to the FMVSS standards in that they only determine compliance with the minimum performance requirements for the direct and indirect vision of HGV drivers. Consequently, neither procedure is wholly appropriate for evaluating the relative differences in the direct vision performance of HGVs.

The target object evaluation method used by UNECE 46 to regulate the forward field of view of larger vehicle drivers is, however, perhaps the most applicable procedure for determining differences in the real-world performance of the direct fields of vision for HGV drivers. By extending the concept to match that proposed by either FMVSS 111 or SAE 1750, this method could be made more appropriate for grading the relative direct visibility performance of HGVs. Again, as no information was provided in regards to any evidence-base behind the rationale underpinning the positioning of the cylinder, further improvements would be required prior to any extension of this technique.

---

## Appendix C Development of a direct vision standard for HGVs

### C.1 Introduction

From the information identified in the review of standards and test methods, the evaluation method for direct vision assessment from HGVs was further developed as described in this Appendix.

From the review of existing methods and the feedback from vehicle manufacturers, the development of the standard was based on a virtual assessment of the field of view using CAD software.

### C.2 Methodology

The review of standards and methods had identified the potential of a 3D target evaluation method to meet the requirements for assessing the direct field of view from HGVs. Initial analysis was completed using three vehicle models; N3G tipper; medium height cab; and low entry cab. The following sections describe initial investigations that were completed using the three vehicle models to help identify key characteristics of the standard.

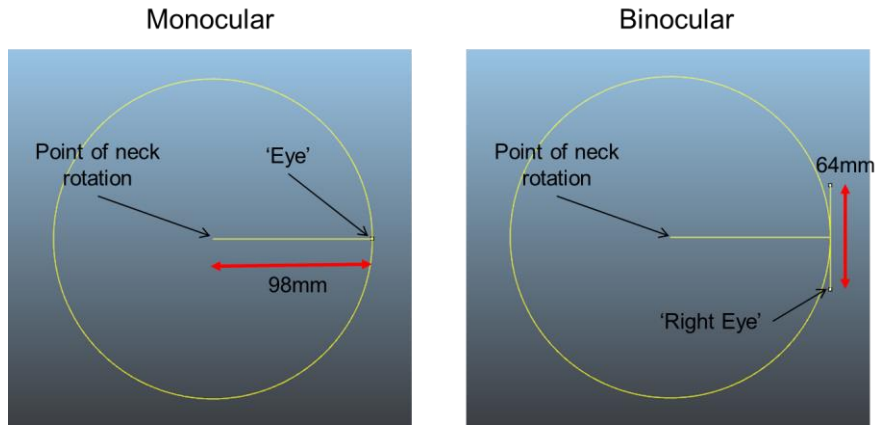
#### C.2.1 Definition of the eye-points

Before starting the assessments of the vehicle models, a two-dimensional comparison on the effect of the type of eye-point was completed. The comparison considered the following eye-point definitions:

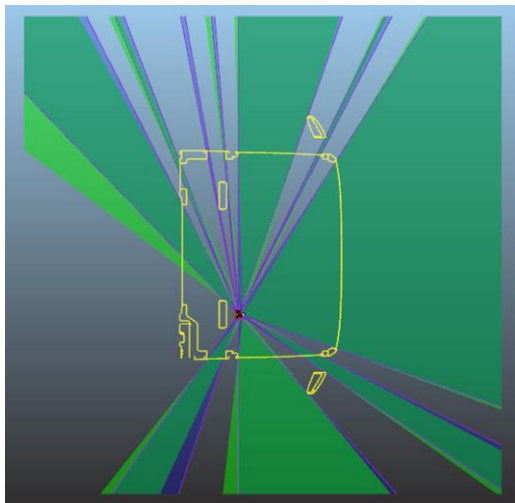
- Monocular fixed – single cyclopean eye-point (midway between the left and right eye) with the head fixed at straight ahead position. This method was considered to be the most basic and least realistic.
- Monocular perpendicular – single cyclopean eye-point that is permitted to rotate about the neck pivot point. While remaining simple, this method is more representative of how the eyes move while driving (although no limit place on head rotation at this time)
- Binocular fixed - A pair of eyes with the head fixed at straight ahead position. This method allowed the view from each eye to be considered, although was not realistic with respect to the head rotation.
- Binocular perpendicular - A pair of eyes that are permitted to rotate about the neck pivot point. This method is considered the most representative of the four scenarios considered (although head rotation wasn't limited for this analysis).

Figure C.1 shows the eye-points and neck rotation points used for this analysis.

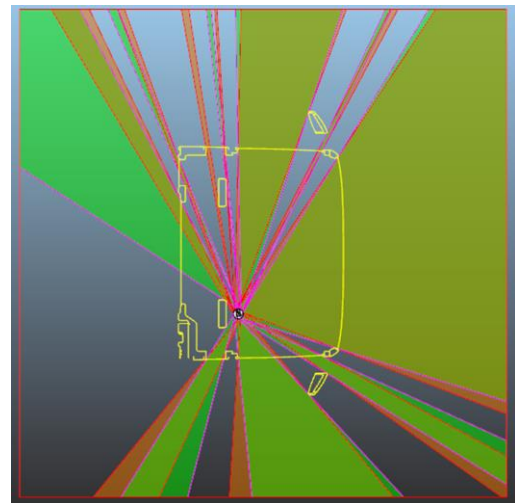




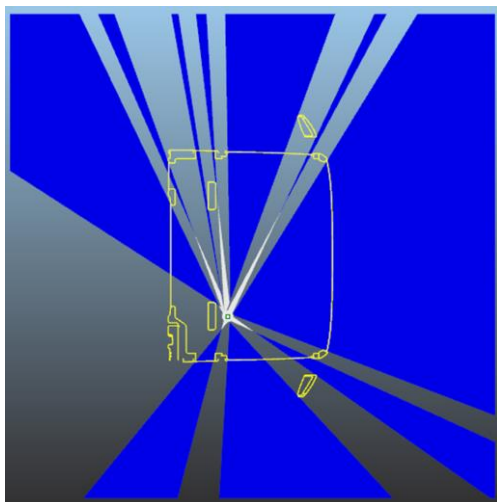
**Figure C.1. Representation of eye-points used for 2D comparison of methods**



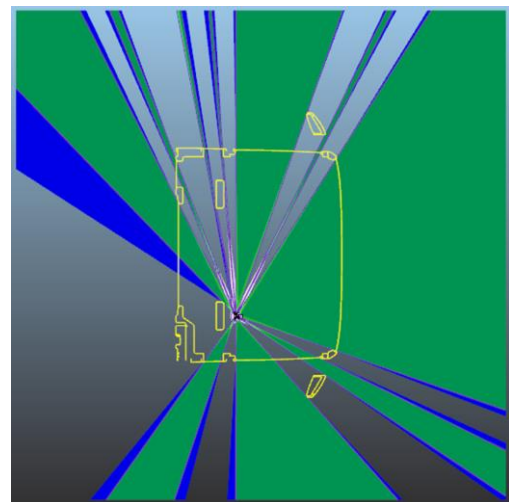
**Monocular: fixed (green) vs rotating (blue)**



**Binocular: rotating – darker shades visible to both eyes**



**Ambinocular: rotating – blue zones visible to at least one eye**



**Monocular rotating vs Ambinocular rotating**

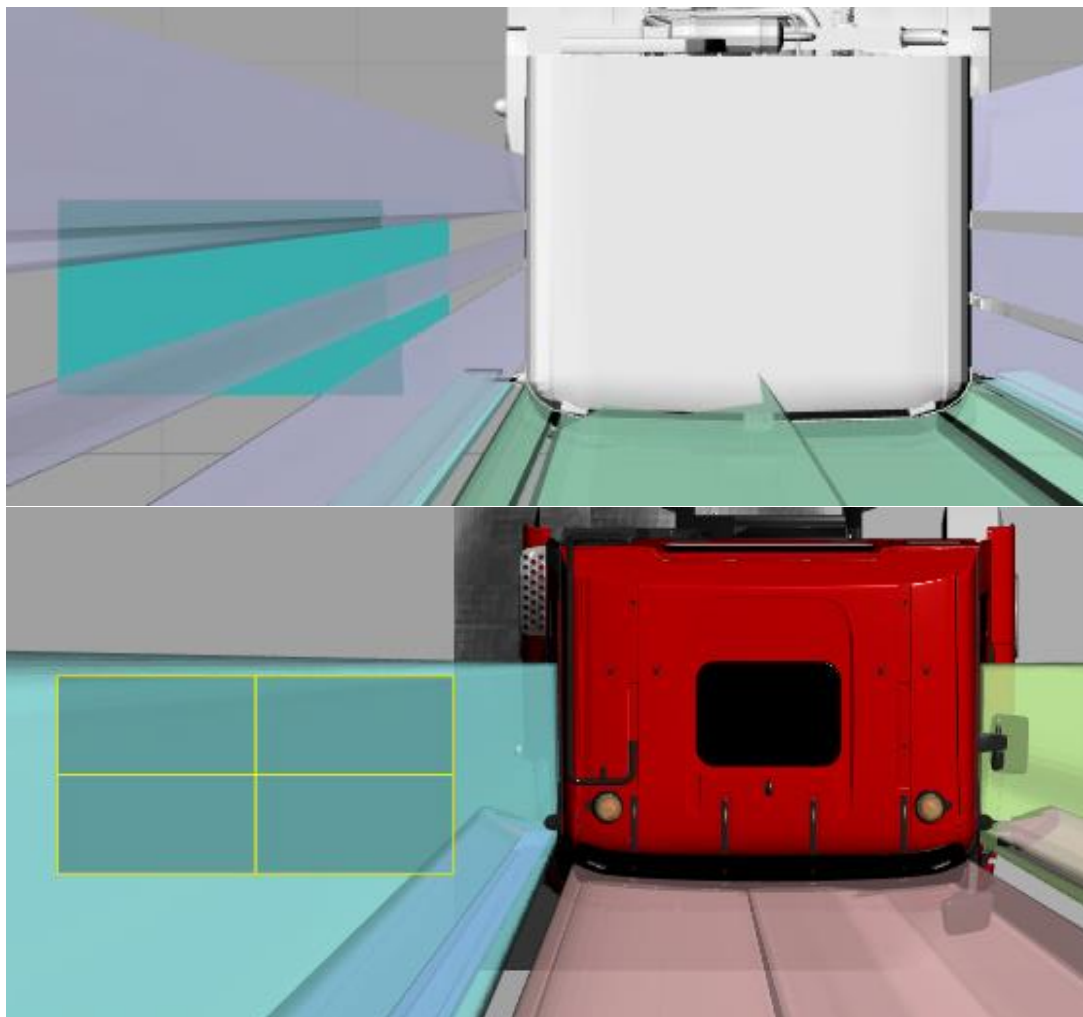
**Figure C.2. 2D comparison of eye-point types**



**C.2.2 Pre-requisite zones**

An initial investigation of pre-requisite zones involved defining planes that must be seen. These vertical planes were intended to represent distant overhead gantry signs and low level signs/traffic signals to the nearside and offside in front of the vehicle. To prevent unintended consequences of increased impacts to the offside of the HGV, a horizontal plane to the offside of the cab was defined. Although the dimensions of the plane were arbitrary, they could have been considered to be a representation of the roof/bonnet of a passenger car.) The plane was placed such that it could be seen by the driver of both the standard N<sub>3</sub>G and N<sub>3</sub> rigid vehicle cabs. The consequence of this was that the plane was not visible for the low cab panoramic vehicle because of the extra door pillars (see Figure C.3). The visible parts are the light turquoise colour that are outside of the vision cones.

This result was counter-intuitive because a greater proportion of the assessment zones were visible for the low cab vehicle. This unexpected result led to further consideration of the pre-requisite zones.



**Figure C.3. Offside pre-requisite assessment for N<sub>3</sub>G and low cab vehicles**

### C.2.3 Generation of visible zones

The assessment environment was designed to ensure that the measurement of the field of view focused on the main areas where it is important for HGV drivers to see pedestrians and cyclists. To ensure that the proposed standard didn't omit any key areas for assessment, the initial analysis considered space around the vehicle that was greater than that defined by the analysis of crash data.

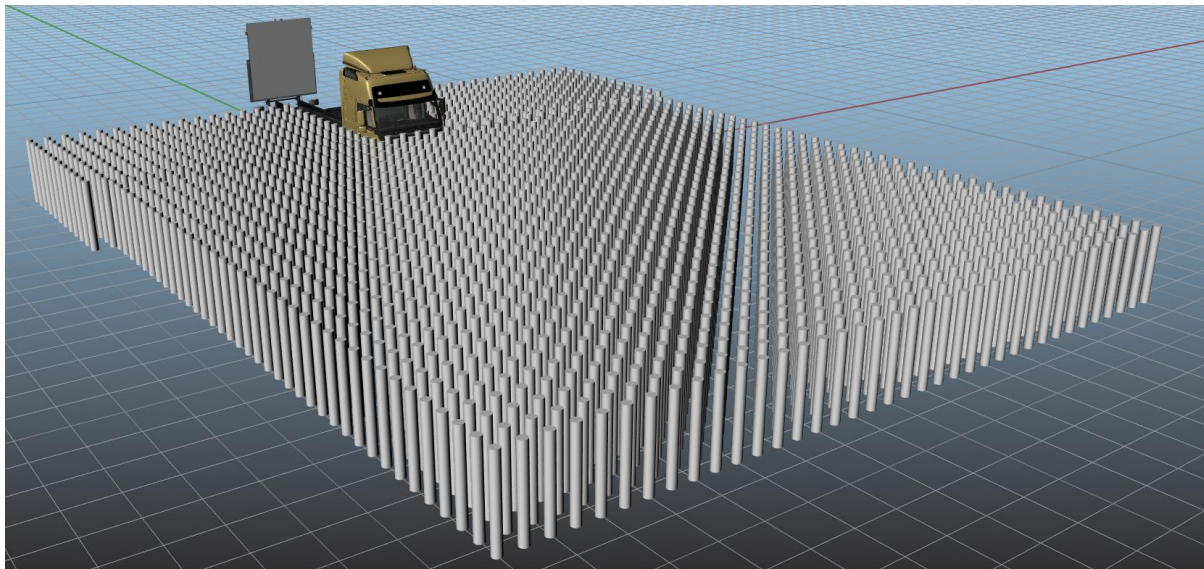


Figure C.4. Initial definition of the assessment zone

## C.3 Results of initial analysis

### C.3.1 Cylinder targets vs volumes

Assessment of the Standard N<sub>3</sub> vehicle with a medium height cab was completed using the cylinder target method. Figure C.5 shows an initial representation of the output from the target assessment method. The green circles represent the target cylinders that were 100% visible and red circles those that were outside the field of view. Circles shaded blue are partially visible to some extent, but there is no differentiation between whether the top, middle or bottom of the cylinder is visible. The visible proportion of the blue marked cylinders is illustrated in the side view shown in Figure C.6. In some cases, only a small portion of the cylinder was visible (labelled #1), or the cylinder was split vertically (labelled #2). For each cylinder, the proportion of the volume visible was calculated.

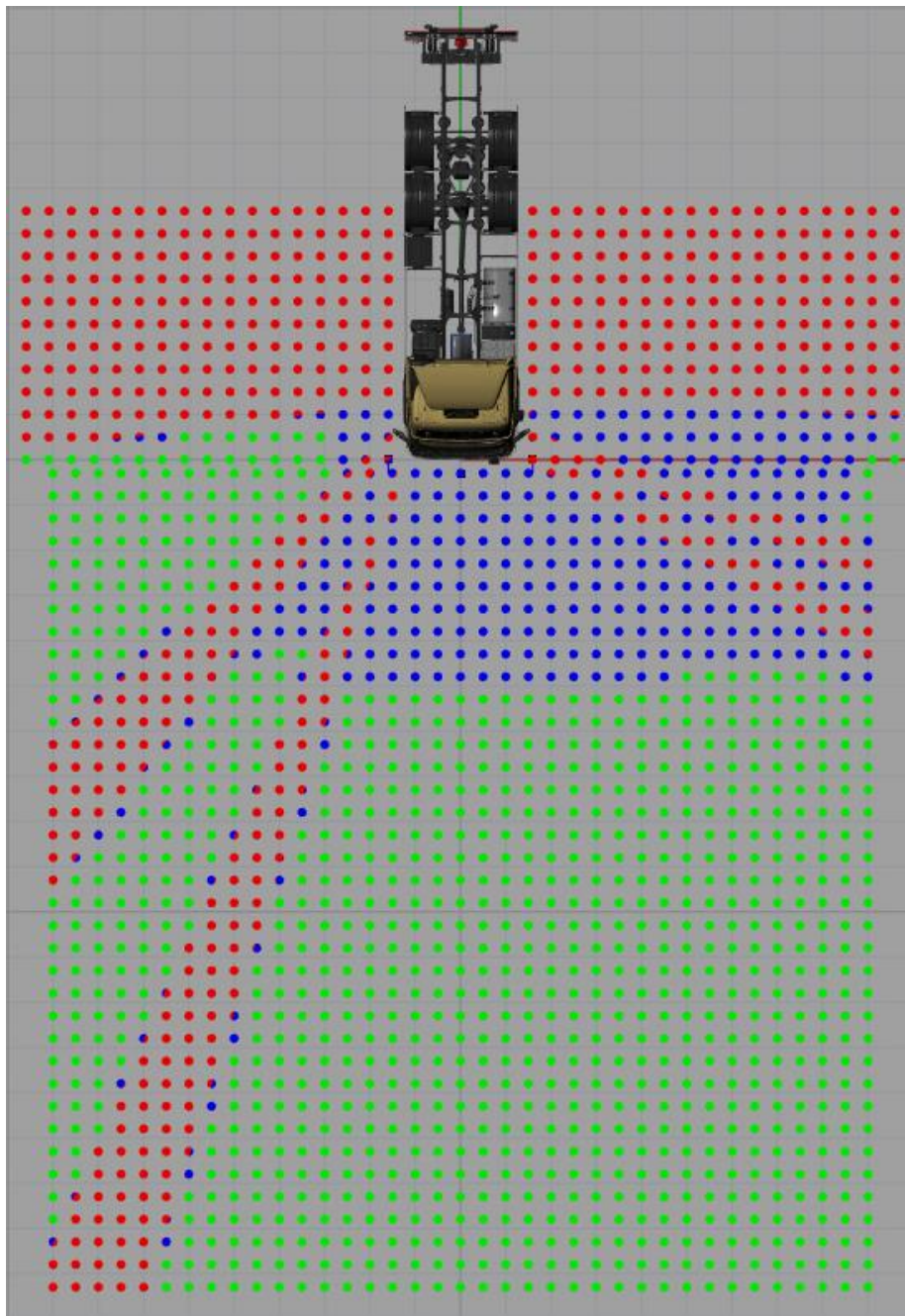


Figure C.5. Representation of output from target (cylinder) assessment method.

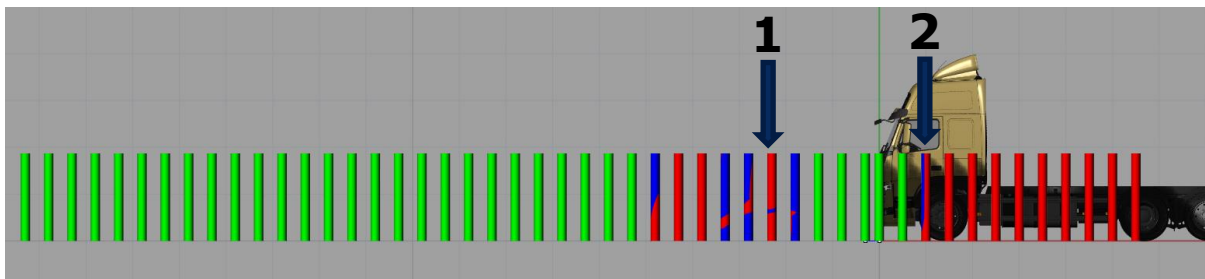


Figure C.6. Offside view of cylinder assessment

---

From this analysis, it became apparent that it would be necessary to control which part of the cylinder was visible, the benefit of seeing from the waist up of the vulnerable road user is more beneficial than seeing the lower legs alone. Tripling the number of cylinder calculations to be carried out had the potential to increase the burden to industry and so alternative approaches were discussed.

The grid of cylinders is an approximation of the total volume in the assessment zone. While the cylinder method lends itself to physical implementation, in a virtual assessment it leaves gaps where potential blind spots could be cast. Switching the assessment method to consider the total volume prevents any “gaps” from being exploited while also reducing the calculation effort, allowing for analysis of the visible zones at different heights from the ground.

Figure C.7 shows the volumetric assessment zones that were used for the initial analysis. The dimensions of the overall assessment zones were matched to that used for the target evaluation method.

Comparison between the visible areas generated by the cylinders and assessment volumes are shown in Table C.1. There was broad correlation between the cylinder target method and the volumetric method over the total assessment volumes. There is a tendency for the volumetric method to measure a smaller visible volume to the front and nearside and a larger volume to the offside.

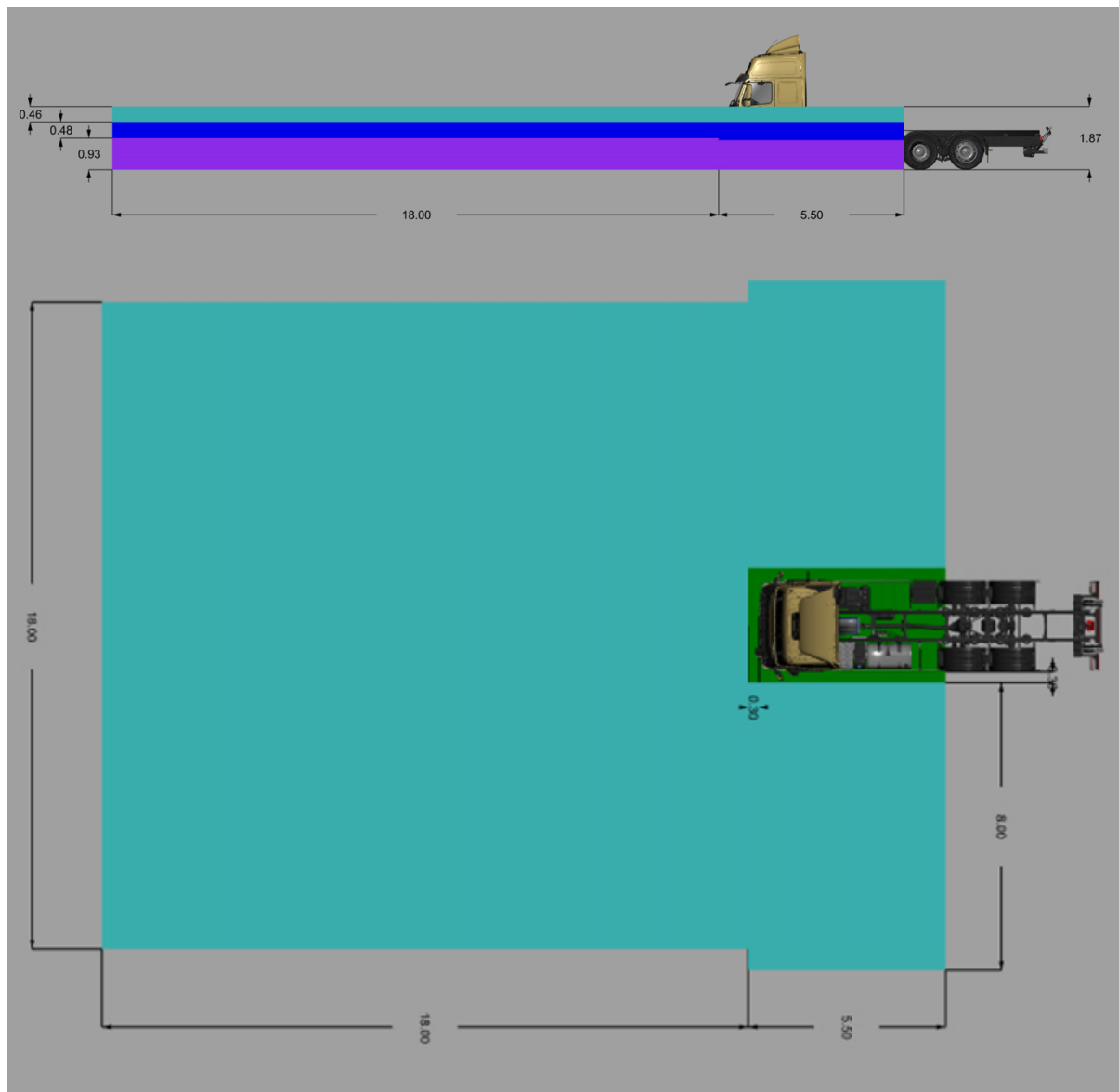


Figure C.7. Volume assessment zones

Table C.1. Comparison of cylinder

	% Visible	
	Cylinder Target	Volumetric
Nearside	16%	13%
Front	84%	82%
Offside	14%	17%



### C.3.2 Comparison of three vehicle models

The results from the initial CAD assessments were compared and the assessment zones were weighted, based on the collision data and the relative importance of the vertical zones. A sensitivity analysis was completed considering a range of different weighting schemes. The different weighting schemes are shown in Table C.3.

The weighting schemes were based upon the distribution of casualties to the nearside, front and offside of the HGVs, both including and excluding the offside zone. The schemes considered how to prioritise the close proximity zones over the larger more expansive zones. Prioritising the vertical zones against each other was also considered. Weighting scheme #2 considered only the close proximity zones, while scheme #7 applied equal weighting to all zones. The close proximity zones were mutually exclusive to their respective wider zone and the scores were normalised to the total weighting applied in the scheme. The results from this initial analysis are shown in Table C.2.

**Table C.2. Results from initial analysis**

	<b>N<sub>3</sub>G</b>	<b>N<sub>3</sub></b>	<b>Low Cab</b>
Weighting #1	0.40	0.43	0.61
Weighting #2	0.31	0.39	0.59
Weighting #3	0.37	0.38	0.58
Weighting #4	0.37	0.39	0.59
Weighting #5	0.38	0.40	0.59
Weighting #6	0.38	0.40	0.59
Weighting #7	0.39	0.39	0.58
Weighting #8	0.41	0.43	0.61
Weighting #9	0.41	0.43	0.61
Weighting #10	0.40	0.47	0.64
Weighting #11	0.41	0.47	0.64
Weighting #12	0.35	0.40	0.59

With the exception of weighting scheme #7, all of the other weighting schemes, ranked the three vehicles in the same order, with the difference between the N<sub>3</sub>G and N<sub>3</sub> vehicles being smaller than the difference between the N<sub>3</sub> vehicle and the low entry panoramic cab. These results were consistent with expectations and demonstrated the ability of the assessment and rating method to differentiate between different vehicle designs. Where equal weightings were applied in scheme #7, there was only a small difference between the N<sub>3</sub>G and N<sub>3</sub> vehicle, suggesting that the assessment needs to include different weightings for the assessment zones.

**Table C.3 Weighting schemes used for sensitivity analysis**

<b>Zone</b>	<b>1</b>	<b>2</b>	<b>3</b>	<b>4</b>	<b>5</b>	<b>6</b>	<b>7</b>	<b>8</b>	<b>9</b>	<b>10</b>	<b>11</b>	<b>12</b>
<b>N/S Priority</b>	0.56	0.56	0.56	0.56	0.56	0.56	1	0.42	1.56	0.56	0.56	0.56
<b>Front Priority</b>	0.44	0.44	0.44	0.44	0.44	0.44	1	0.5	1.44	0.44	0.44	0.44
<b>N/S Top</b>	0.56	0	0.2	0.1	0.2	0.25	1	0.51	0.51	0.051	0.102	0.042
<b>N/S Middle</b>	0.56	0	0.2	0.25	0.3	0.25	1	0.51	0.51	0.1275	0.153	0.105
<b>N/S Lower</b>	0.56	0	0.2	0.05	0	0	1	0.51	0.51	0.0255	0	0.021
<b>Front Top</b>	0.44	0	0.2	0.1	0.2	0.25	1	0.41	0.41	0.041	0.082	0.05
<b>Front Middle</b>	0.44	0	0.2	0.25	0.3	0.25	1	0.41	0.41	0.1025	0.123	0.125
<b>Front Lower</b>	0.44	0	0.2	0.05	0	0	1	0.41	0.41	0.0205	0	0.025
<b>O/S Top</b>	0	0	0.2	0.1	0.2	0.25	1	0.09	0.09	0.009	0.018	0.042
<b>O/S Middle</b>	0	0	0.2	0.25	0.3	0.25	1	0.09	0.09	0.0225	0.027	0.105
<b>O/S Lower</b>	0	0	0.2	0.05	0	0	1	0.09	0.09	0.0045	0	0.021



### C.3.3 Effect of design changes

The proposed standard has been shown to differentiate between three different vehicle types. This section looks at the ability of the standard to differentiate changes to the design of a specific vehicle. This analysis was completed using eh N3G vehicle model. The design modifications were:

- Addition of a low window in the nearside door – the window was considered the best case that could be achieved for that vehicle, and did not account for reality of such a window being incorporated in that vehicle design. This change will have greatest effect on the ability of the driver to see the zones to the nearside of the vehicle, and potentially some benefit to the frontal zones.
- Removal of the dashboard – for this vehicle, the lower edge of forward vision was limited by the dashboard. Therefore, removing the dashboard allowed the effect of lowering the window edge to be considered. This change will provide benefit for the driver to be able see the frontal zones of the assessment environment.

The results from these assessments were combined with the initial results from the three vehicles to allow the visibility scores to be compared. The range of weighting schemes was also applied as before with the results shown in Table C.4.

**Table C.4. Results for design modifications against the three original vehicle models**

	<b>N<sub>3</sub>G</b>	<b>N<sub>3</sub>G low window</b>	<b>N<sub>3</sub>G no dash</b>	<b>N<sub>3</sub> rigid</b>	<b>Low cab</b>
Weighting #1	0.40	0.42	0.41	0.43	0.61
Weighting #2	0.31	0.33	0.34	0.39	0.59
Weighting #3	0.37	0.38	0.38	0.38	0.58
Weighting #4	0.37	0.38	0.38	0.39	0.59
Weighting #5	0.38	0.39	0.39	0.40	0.59
Weighting #6	0.38	0.40	0.40	0.40	0.59
Weighting #7	0.39	0.41	0.40	0.39	0.58
Weighting #8	0.39	0.41	0.41	0.42	0.60
Weighting #9	0.39	0.41	0.41	0.42	0.60
Weighting #10	0.34	0.36	0.37	0.40	0.60
Weighting #11	0.35	0.37	0.38	0.41	0.60
Weighting #12	0.36	0.37	0.38	0.41	0.60

The results again show a consistent rank order, with the exception of scheme #7, however the differentiation between the different designs of the N<sub>3</sub>G vehicle are not always present.

In order to identify if the size of the assessment zone was masking the difference in performance, it was therefore necessary to further look at the geometry of the assessment zones.

### C.3.4 Refinement of the assessment zones

To ensure that the proposed standard didn't omit any key areas for assessment, the initial analysis considered space around the vehicle that was greater than that defined by the analysis of crash data.

The size of the overall assessment volumes are large when compared to the close proximity zones defined based on the collision data. To investigate the effect of the size of the frontal assessment volume on the sensitivity of the analysis and the ranking of vehicle designs, the extent of the zone in the longitudinal direction was reduced from 18m to 10m.

**Table C.5. Results for 10m frontal volumetric zone**

	<b>N<sub>3</sub>G</b>	<b>N<sub>3</sub>G low window</b>	<b>N<sub>3</sub>G no dash</b>	<b>N<sub>3</sub> rigid</b>	<b>Low cab</b>
Weighting #1	0.37	0.42	0.39	0.42	0.59
Weighting #2	0.31	0.33	0.34	0.39	0.59
Weighting #3	0.35	0.38	0.37	0.37	0.56
Weighting #4	0.35	0.38	0.37	0.38	0.57
Weighting #5	0.37	0.39	0.38	0.39	0.58
Weighting #6	0.37	0.39	0.38	0.39	0.58
Weighting #7	0.37	0.40	0.38	0.38	0.56
Weighting #8	0.38	0.42	0.40	0.42	0.59
Weighting #9	0.36	0.39	0.38	0.41	0.59
Weighting #10	0.33	0.36	0.36	0.40	0.59
Weighting #11	0.34	0.37	0.37	0.41	0.59
Weighting #12	0.34	0.37	0.37	0.39	0.58

The results show that there is now a clear trend for the lowest and highest ranked vehicle across all weighting schemes, including #7. However, there is still a less clear trend for the modified and intermediate vehicle designs. The vehicle with the dashboard removed is now generally ranking lower than the vehicle with the additional side window in most schemes. This suggests that defined volumes for each zone can have a strong influence on the ranking.

There is no clear evidence to support the geometry of the larger assessment volumes. Because changes to these volumes can influence the ranking outcome of comparison of different vehicle designs, it was proposed that the Direct Vision Assessment Protocol should only consider the close proximity zones on the nearside and front of the vehicle. This approach is highlighted by weighting scheme #2 which has also shown the clearest differentiation between the vehicle designs.

The initial close proximity zones were not defined with difference in height as the wider volume had been. It is therefore essential that the close proximity zones be modified to include this differentiation.

Removal of the wider assessment volumes also results in a zone to the front nearside that will not form part of the assessment. It is therefore proposed to extend the nearside zone forwards.

The final assessment zones proposed for the Direct Vision Assessment Protocol are shown in Figure C.8 (dimensions in metres). The four zones are mutually exclusive.

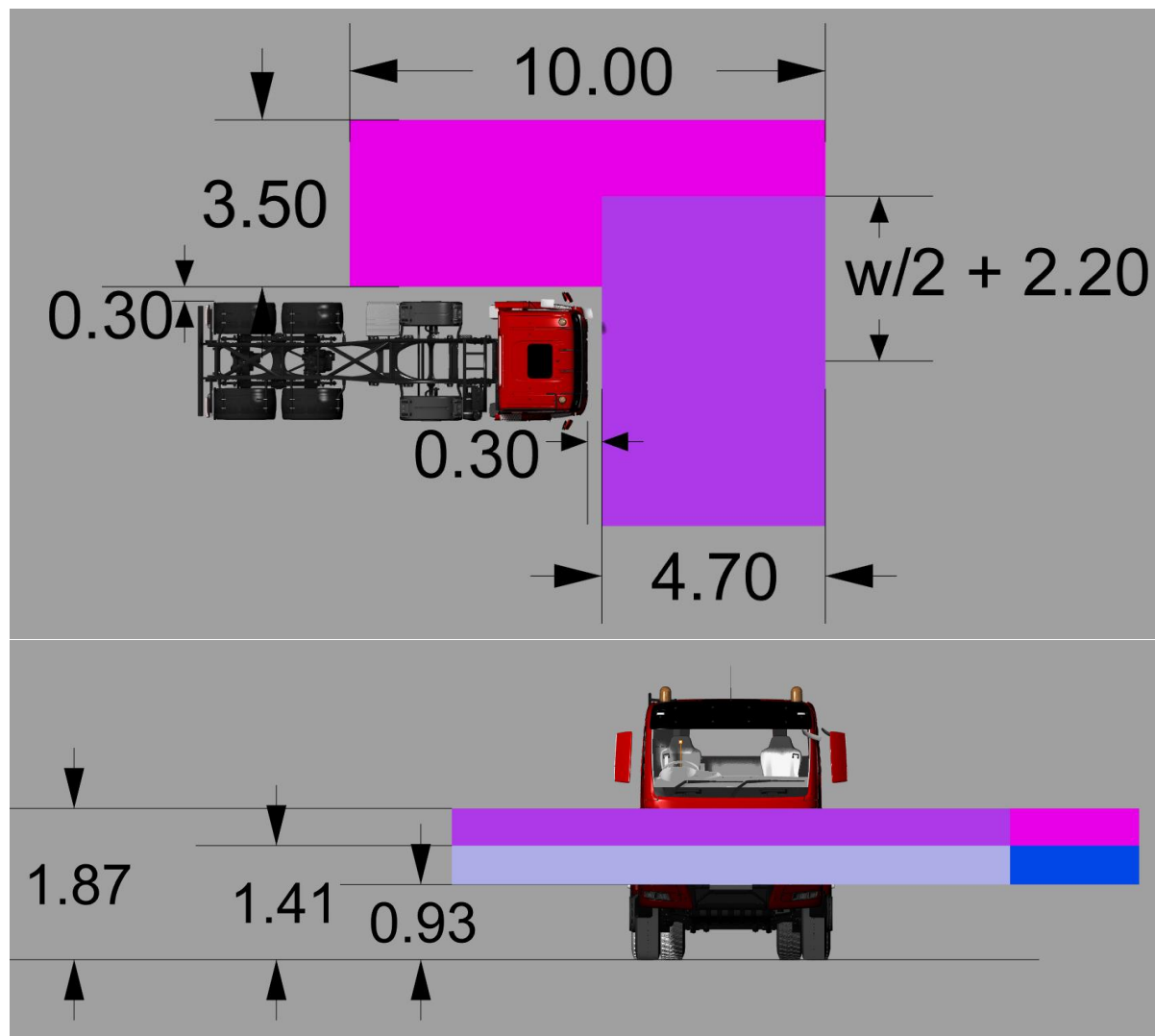


Figure C.8. Proposed assessment zones

#### C.4 Verification of proposed draft standard

To verify the proposed Direct Vision Assessment Protocol, the analysis of the three original vehicles was repeated, including the two design modifications to the N<sub>3</sub>G vehicle. An additional long haul vehicle (articulated) was added for assessment and comparison. A sensitivity analysis to consider the effect of the weightings applied (similar to that previously completed) was completed. The weightings are shown in Table C.6.

**Table C.6. Weightings applied to close proximity zones**

Zone	Weighting Scheme #				
	1	2	3	4	5
Nearside Upper	1.00	0.56	0.56	0.56	0.19
Nearside Lower	1.00	1.12	0.56	1.68	0.37
Front Upper	1.00	0.44	0.44	0.44	0.15
Front Lower	1.00	0.88	0.44	1.32	0.29

The results from this analysis are shown in Table C.7

**Table C.7. Sensitivity analysis for weightings applied in the Direct Vision Assessment Protocol**

	N <sub>3</sub> G	N <sub>3</sub> G low window	N <sub>3</sub> G no dash	N <sub>3</sub> artic	N <sub>3</sub> rigid	Low cab
Weighting #1	0.45	0.46	0.48	0.58	0.52	0.68
Weighting #2	0.40	0.42	0.43	0.53	0.48	0.66
Weighting #3	0.42	0.44	0.45	0.55	0.50	0.66
Weighting #4	0.39	0.41	0.42	0.53	0.46	0.65
Weighting #5	0.40	0.42	0.43	0.53	0.48	0.66

In addition, the sensitivity to the collision data used to generate the weightings was also completed. This analysis is summarised in Table C.8

**Table C.8. Sensitivity of Direct Vision Assessment Protocol to collision data used for generating weightings.**

	N <sub>3</sub> G	N <sub>3</sub> G low window	N <sub>3</sub> G no dash	N <sub>3</sub> artic	N <sub>3</sub> rigid	Low cab
10 year - London	0.39	0.41	0.42	0.53	0.46	0.65
5 year - London	0.36	0.38	0.39	0.49	0.43	0.63
3 year - London	0.41	0.43	0.45	0.56	0.49	0.67
10 year - GB	0.44	0.46	0.49	0.59	0.52	0.69
5 year - GB	0.44	0.46	0.49	0.60	0.53	0.70
3 year - GB	0.44	0.45	0.48	0.59	0.52	0.69

For the vehicles assessed, the rank order is not affected by the weightings applied; either the collision data behind the weightings or the relative importance of the upper and lower zones. The assessment protocol has therefore used the 10 years of data for London to

generate the weightings applied to the front and nearside zones. Weighting scheme #4 has been proposed because the collision and anthropometric data suggests that the lower zones should have a higher importance. Scheme #4 was selected over scheme #2 because it was considered to provide a higher incentive to improve visibility in zones that would be applicable to a larger proportion of VRUs.

Table C.9 shows the boundaries for the rating scheme that have been defined based on the results of the analysis of the eight vehicle designs.

**Table C.9. Vehicle rating boundaries as defined for TfL Direct Vision Assessment Protocol.**

Star rating	Rating boundaries
0 Stars	$\geq 0$ and $\leq 0.40$
1 Star	$> 0.40$ and $\leq 0.45$
2 Stars	$> 0.45$ and $\leq 0.50$
3 Stars	$> 0.50$ and $\leq 0.55$
4 Stars	$> 0.55$ and $\leq 0.60$
5 Stars	$> 0.60$ and $\leq 1.00$

Table C.10 shows how the vehicles were rated using the assessment protocol, including the additional analysis of a modified N<sub>3</sub> rigid vehicle (adding low side window, removing dashboard).

**Table C.10. Results from the application of the direct vision assessment protocol**

Star rating	Vehicle type assessed	Actual score
0 Stars	Standard N <sub>3</sub> G vehicles	0.39
1 star	N <sub>3</sub> G vehicle baseline or with with single vision enhancements	0.41-0.42
2 stars	N <sub>3</sub> rigid vehicle baseline or with single vision enhancements	0.46-0.49
3 stars	N <sub>3</sub> rigid vehicle with multiple vision enhancements <sup>14</sup> N <sub>3</sub> articulated vehicle	0.52 0.53
4 stars	None of vehicles assessed	N/A
5 stars	N <sub>3</sub> Low entry cab	0.65

### C.5 Vehicle 3D-scanning procedure

It was concluded in Section 5.2 that an informative set of instructions for laser scanning of a vehicle should be developed to provide guidance in the generation of a 3D vehicle

<sup>14</sup> Estimate based on combing scores for additional side window and removed dashboard – not fully assessed.

model. TRL developed a procedural description that contains information on the test equipment and conditions required, and provide instruction for setting up the vehicle and performing the visibility scans and post-processing of the data. The procedure recommends a series of seven laser scans from different positions inside and outside the cab, and subsequent combination of the scan data into one 3D point cloud model. Subsequently, a 3D surface model (CAD model) may be created from this data, which improves handling of the model in software. This is an optional step, however, because the field of view can also be evaluated and assessed directly from the point cloud model. The instructions are attached to the TfL Direct Vision Protocol as informative Annex C, Vehicle 3D-scanning procedure.

The minimum requirements for equipment regarding accuracy and resolution of the laser scanner were based on the minimum model accuracy required for evaluation and assessment part of the TfL Direct Vision Protocol. It was verified that common scanners on the market can achieve these values, for instance FARO Focus 3D or RIEGL VZ models.

Restrictive prescriptions of test conditions (such as indoor conditions or a narrow temperature range) are not required for this procedure, because laser scanners are commonly specified for use in indoor and outdoor conditions and in a wide temperature range. Moreover, some scanner models use GPS signals, which is why outdoor conditions even may be advantageous for some scanners. However, rainy conditions need to be avoided because rain drops reflect the laser beams which would increase noise in the model or render the scan unusable.

Seven laser scans are recommended as a minimum number (from five positions outside and two positions inside the cab). Based on experience from TRL's HGV scanning and the CLOCS/LDS-2015 work, this number allows capturing the relevant features of the cab with sufficient detail. The time required for a laser scan is highly dependent on the equipment and the chosen resolution. Using typical laser scanner, such as a FARO Focus 3D, the required scan quality will be achievable with a duration of 30 minutes or less per scan.

Note: The layout of the TfL Direct Vision Protocol was designed to follow guidelines for ISO standards, which specify two different types of annexes: Normative and informative. Test procedures that must be performed when applying the standard (mandatory) form normative annexes, whereas procedures that may be omitted (optional) are described in informative annexes. The 3D-scanning procedure is optional because it is not necessary to perform it when a CAD model already exists, for example at the manufacturer, and was hence described in an informative annex, which cannot make definitive prescriptions but only give recommendations. This is reflected, for instance, by using 'should' rather than 'shall' throughout the Annex.

## Appendix D Stakeholder feedback

For this project, stakeholder groups have been identified as vehicle manufacturers, vehicle operators and regulators, all of which will have a vested interest in the outcomes of this project. A brief stakeholder analysis was undertaken which:

1. Identified stakeholders
2. Prioritised them to determine their power, influence and interests
3. Assessed which stakeholders are most important and how they are likely to respond

### D.1 Vehicle Manufacturers

Detailed discussions were held with five vehicle manufacturers and preliminary discussions took place with one more. The overall view of the proposal was mixed. All vehicle manufacturers understood and accepted the need to improve vulnerable road user safety. However, some manufacturers were enthusiastically positive about achieving this through improved direct vision while others quite strongly questioned the effectiveness and the cost and considered that there were better ways to solve the problem.

#### D.1.1 Design and commercial implications

Low entry cabs have been identified in the previous work as the ‘best in class’ standard for direct vision and no manufacturers disputed this. All agreed it involved fundamental cab re-design to provide a low entry cab. However, several pointed to several constraints with the design. It was agreed that the reduced cab height, in all existing designs, was achieved by moving the cab forward on the chassis such that it could be dropped down in front of the engine and chassis rails. This leads to a reduced height at the front edge of the vehicle and an increased front overhang, which combine to substantially reduce the maximum approach angle. Several manufacturers considered this likely to restrict off-road capabilities and while they accepted that sites that TfL could influence may improve such that off-road capability was less important, not all other sites would or could be improved. Building demolition sites were cited as one of the most difficult to deal with.

In addition to this, the revised cab geometry tended to mean the driver sat in front of the front axle, changing the motion experienced during turns. The overall length of the vehicle was increased for the same load space and the manoeuvrability decreased in terms of overall swept path. There was less space available for the engine and reduced cooling which placed limits on engine size and power. Thus, most manufacturers agreed a low entry cab would not be well suited for all applications and at least one considered the increased length and reduced manoeuvrability a potential additional risk for VRUs in turning manoeuvres. Load distribution could also be affected for four axle vehicles because low cab designs did not use two front axles (1 front, 3 rear). Axle load regulations make 32 tonnes harder to achieve in this configuration leaving very little scope for centre of gravity position to change at GVW without exceeding axle weights.

Low entry cabs tended to cost substantially more than traditional designs (+£10k to £20k) but this was partly because they tended to use specialist gearboxes as well as the additional cost of a ‘niche’ vehicle design and different materials etc.



Reducing overall height more modestly (e.g. N3G to N3 spec) was seen as a positive benefit that would be achievable in many applications.

Opinions regarding the addition of windows in the passenger doors were more mixed. One respondent said that they did not think it would make much difference in practice because it would end up obstructed by clutter/passengers inside the cab or by dirt on the window itself and could increase driver workload (6 mirrors, windscreen and two nearside windows to monitor). In addition they considered it would only provide a partial view of a cyclist in one specific position adjacent to the vehicle such that if the cyclist was moving relative to the vehicle, only a glimpse view would be achieved. However, they intended to implement it as a retro-fit costing in the region of £2,500 per vehicle in order to be compliant despite these reservations. By contrast, a different manufacturer thought that there were potential benefits to a low level door window and pointed to Japan as a market where it was common. However, they would not support retro-fitting of a window because they considered it would compromise the crashworthiness of the cab and invalidate type approval to R29. They would only consider it as an original equipment design which would involve several years lead time to implement.

Most manufacturers could foresee taking advantage of the extra length to be permitted through proposed changes to the lengths and dimensions regulations to produce cabs with a profiled nose that could improve direct view. However, they saw aerodynamic benefit as the primary motivation for such changes and thought they would be restricted to long haul vehicles only.

Several manufacturers referred to the use of cameras and in particular 360 degree surround view cameras as an alternative solution at much lower cost. One manufacturer was actively looking at replacing one or more mirror views with cameras, depending on evolution of the Regulations. One manufacturer stated that proximity sensors and collision warnings would be a better solution. Two manufacturers confirmed that they were working on evolutions of their AEBS such that they would be sensitive to VRUs and work in left turns. Several manufacturers saw this as the ultimate solution, despite some concerns about cyclists relying on HGVs being equipped and using it to force HGVs to give them priority.

Only two manufacturers stated that they had seen consumer demand for improved vision cabs, both citing direct response to the CLOCS initiatives. All saw demand for 'Clocs compliant' vehicles but considered that operators often did not really understand what that meant and in one case the manufacturer wasn't sure, stating that it was more relevant to body builders.

In general, most manufacturers saw the main barriers to improved direct vision as cost and lead time. This related to the high cost and long life of cab designs. Most manufacturers considered that the London construction vehicle market was insufficient for them to substantially change cab design such that if their vehicle range ended up being non-compliant they would simply not sell into that market. All urged TfL to consider applying requirements through EU Type Approval rather than as a local initiative, to help overcome this barrier.

### **D.1.2 Technical Elements**

Many of the manufacturers consulted did not have strong views on the exact technical methods to be used. In general the views expressed were as follows:

- Most but not all preferred the SAE approach to rating (cylinders on a flat plane) though one preferred spherical projection
- Most favoured a simplified approach to minimise burden but some preferred a more fidelic approach to guarantee fairness
- All preferred a virtual approach where one vehicle measurement could be used to assess a range of variants with different cab mounting heights but otherwise similar features. However, some still saw diversity of designs as a problem and considered it necessary to define a simplified regime to minimise burden (e.g. measure best case and worst case and define the variants the range was valid for).
- Some manufacturers preferred the idea of self-certifying the performance of their vehicles (with occasional independent spot checks) but some considered independent evaluations would be better in order to ensure a level playing field.
- One manufacturer considered that mirror clusters should be ignored in the assessment because the obstruction to direct vision that they cause would give manufacturers an incentive to design down to the minimum regulatory standard for direct vision (which they said many voluntarily exceed). Another considered that they should be included to encourage clever design that ensured the obstructed area was minimised, for example by 'hiding' them partially behind the A pillar to minimise the overall obstruction.

## **D.2 Vehicle Operators**

Having identified the stakeholders, initial contact was made to gauge their thoughts and understanding of direct vision within the HGV industry and their buy-in to the project outcomes. The consultation was undertaken through telephone interviews with the 20 operators listed in with the aim of covering a range of industries.

**Table D.1. List of participating operators**

<b>Company/Category</b>
<b>3PL</b>
Wilson James
Wincanton
<b>Construction</b>
Cemex
Day Group
Erith
SIG
Thames Tideway Tunnels
Travis Perkins
<b>General Haulage</b>
DHL
JD Commercials
<b>Plant Hire/Construction</b>
L Lynch
<b>Ports</b>
Peel Ports
<b>Rail Transport</b>
Crossrail
HS2
<b>Retail</b>
DHL – Nisa
Next
Sainsbury
<b>Utilities</b>
Thames Water
<b>Waste/Recycling</b>
EMP
O'Donovan (Waste Disposal) Ltd

**D.2.1 Discussion prompts**

The following prompts were used as discussion topics with each operator:

- How and where do you think direct vision on HGVs can be improved? (Direct vision is what a driver can see through the windscreen, side windows and rear windows if fitted and does not include the use of mirrors and cameras.)

- Is there an ideal vehicle or a range of vehicles on the market today?
- Do you notice a difference in direct vision between the different makes of vehicle you have operated/are operating?
- If so, which vehicles do you think are the best and the worst of the current fleet of vehicles available?
- What are the key 'must haves' when purchasing a new vehicle for your operations? (Specification based)
- When purchasing a new vehicle, where would direct vision be placed in the priority list?
- What other constraints do you have when purchasing vehicles? (Such as financial, fleet replacement plan, servicing & maintenance, existing fleet etc.)
- Have you or would you consider a low entry/low floor option design of vehicle (Mercedes Econic as an example) for your operations?
- What are/or would be the constraints of using a vehicle like this for your operation?
- What specific constraints (vehicle choice, spec, etc.) do you have in relation to your operation, which other operators may not share?
- If a minimum standard of direct vision on vehicles was imposed on all operators working in London, what would be your reaction?
- If a standard defining direct vision performance was available how would operators use them?
- What would operators need for them (the standards) to be best understood?

### ***D.2.2 Key themes***

The following highlights some of the key themes resulting from the interviews. The detailed notes are contained within Annex 1.

#### *D.2.2.1 Considerations*

##### Timescales for any standards being introduced.

Many operators considered the timescales for any standards being introduced is key in understanding the cost implications and the ease of implementation. The shorter the timescale for required compliance the more costly it becomes, which inevitably impacts costs within the wider supply chain.

##### Consider other aspects of vehicle movements as well as technical specifications such as driver training and awareness of specific other road users.

Whilst having a specification for the vehicle visibility this, in isolation, will not resolve all the issues. A more holistic approach needs to be taken to include driver training on how to make the most of the better visibility, as well as working on gaining greater awareness between all users of the city's roads.

##### Cost implications

Linked to some extent with the timescales, any changes will inevitably result in a cost and therefore, ‘how can costs be shared between different parties within the supply chain rather than the operators perceiving that they are bearing all the cost?’

Ability to use vehicles in different environments, for example existing Econics don’t work in all environments and therefore creates an inflexible fleet.

Many operators identified the limitations of the Econics which leads to having an inflexible fleet by only being fit for purpose in specific environments. This may be true of other types of low floor/wide window options, therefore consideration needs to be given to creating standards that can be applied to urban, rural and motorway environments.

#### *D.2.2.2 3.2 Risks*

Too many standards for companies to meet across a range of issues.

From the operations perspective there are many standards that already needs to be complied to; FORS, CLOCS, Cross Rail. Having another standard in addition will lead to more confusion and cost being incurred.

Sensory overload of drivers with the amount of indirect vision tools and then adding more “visibility” through direct vision could add more pressure for a driver.

Regulators/policy makers may need to consider taking some tools away to simplify the driving experience and allowing the driver to concentrate, or find solutions that enable drivers to get the best vision possible without causing distraction.

“let’s assess the risk” – is there a list of priorities, things that are more important than others? What vehicles are the greatest risk and address them first.

There was a concern that all HGV’s and all industries present the same risk. Some operators requested confirmation of the size of the problem and which particular sectors, if any, present the greatest challenge, rather than potentially providing solutions to problems that don’t exist.

Potential risk that the solutions proposed don’t solve the problem and therefore need to be sure that any standards make a real difference.

Key to the successful implementation of the standards is that the solutions do make some inroads into resolving the real problems. Whilst improved direct vision will help it cannot alone resolve all blind spots nor overcome poor awareness of the interactions between different road users.

#### *D.2.2.3 Solutions*

A concern that this is London specific and what impact this would have on flexibility of fleet for national operators.

Similar to making sure any specification driven solutions can be used in multiple environments, is that while the standards are London centric it creates a restriction on operators. In addition to this, if higher specification vehicles are used outside of London this could price operators out of contracts by having higher specified vehicles than what is required.

Standards need to be clear and specific.

Any standards created cannot be open to any interpretation thus allowing misunderstanding and will not create a level playing field.

There isn't really an off the shelf existing solution.

Whilst some manufactures have made a few efforts to incorporate direct vision into their specifications, there is not a standard vehicle that has significant improvements in direct vision.

Greatest concern is that it's not done with EC standards in mind.

It is essential that consistency is achieved across borders to both achieve a level playing field and to help create a demand so that manufactures will come up with technical solutions to the issues.

Needs to be more joined up thinking rather than just "blaming" the HGV operators.

It is critical that to achieve a sustainable solution for vulnerable road users that it is part of an integrated approach which includes driver training, awareness between road users and a shared burden of cost.

Sweetener for those who do the right thing in a timely manner.

If operators are having to implement changes, providing an incentive above and beyond compliance would help to provide timely implementation.

Direct vision not really a priority at the moment in the specification and procurement process.

There are currently many other factors that would take precedence over direct vision, however, if standards were proposed this would help to raise the profile of the issue with buyers.

*D.2.2.4 Others*

Loughborough University study mentioned a number of times as a source of guidance

The design of category N3 vehicles for improved driver direct vision, prepared for Transport & Environment / Transport for London by Loughborough Design School, Loughborough University

# Definition of Direct Vision Standards for Heavy Goods Vehicles (HGVs)



## Other titles from this subject area

**Type report no. here** Type report details here. Format: Title. Authors. Year

**Type report no. here** Type report details here. Format: Title. Authors. Year

**Type report no. here** Type report details here. Format: Title. Authors. Year

**Type report no. here** Type report details here. Format: Title. Authors. Year

## TRL

Crowthorne House, Nine Mile Ride,  
Wokingham, Berkshire, RG40 3GA,  
United Kingdom  
T: +44 (0) 1344 773131  
F: +44 (0) 1344 770356  
E: [enquiries@trl.co.uk](mailto:enquiries@trl.co.uk)  
W: [www.trl.co.uk](http://www.trl.co.uk)

ISSN

ISBN

**CPR2278**



